

H-DRIVE EHD OPERATOR

EXTRA HEAVY DUTY OPERATORS FOR VERY LARGE SPRING-BALANCED ROLLER SHUTTERS



HH403M

The H-Drive EHD range is designed for very large spring-balanced roller shutters up to 120m². Fan-cooled motors and a robust gearbox combine to offer a durable and long service operator to withstand extreme workloads.

Key Features

- Powerful 4.0Hp motor with purpose designed gearbox for durable, reliable operation
- Ideal for very large spring-balanced roller shutters up to 120m²
- Controlled with a Reversing Starter
- Rated for high duty cycle (30% run time)

What's in the Box?

H-Drive EHD Operator.
All wall controls and mounting hardware available separately.

Information for Roller Shutters

All operators have a recommended maximum Roller Shutter area listed in the specification table. All recommended sizes are based on a "Standard Roller Shutter" (refer below):

- The Shutter is correctly spring-balanced
- The Shutter has $\leq 1.0\text{mm} \times \geq 100\text{mm}$ slats
- 200mm diameter drum is used
- The Shutter has no wind-locks
- A sprocket ratio $\geq 4:1$ is used

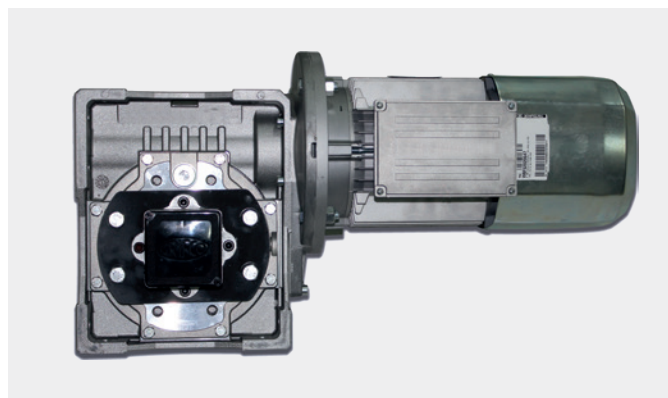

Product may differ slightly from images shown.

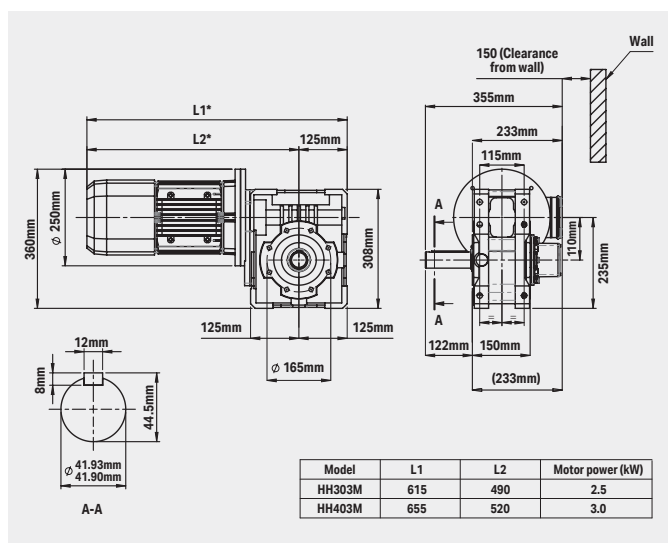

Model Details

Part No. HH403ML (81500L) or HH403MR (81500R)

Description H-Drive EHD RSO H/C 4.0Hp 415V 3PH IP55

(L/R) indicates which side of the door opening the motor is mounted to (when viewed from inside the building). For example a model with an "L" suffix is mounted to the top left of the door opening.

Optional Controller

Part No. RG374-LB3E010

Description Reversing Starter for basic Up / Stop / Down Control

Controller sold separately. Please refer to the relevant Specification Sheet for details.

Specifications

kW	3.00kW	Phase	3ph
Amps	5.88A	Max SB Door Size	120m ²
Hp	4.0Hp	IP Rating	IP55
Voltage	415V	Duty Cycle	HC

HC = High cycle (30% run time / hour).

Upgrades

No Neutral (N)	N/A
Pre-Wired (P)	N/A
IP55 (W)	N/A
Clutch (C)	N/A

Upgrades:
O = Optional
S = Supplied as standard
N/A = Not applicable

GSS-HH403M