

Fire Shutter

Industrial Fire Shutter Opener

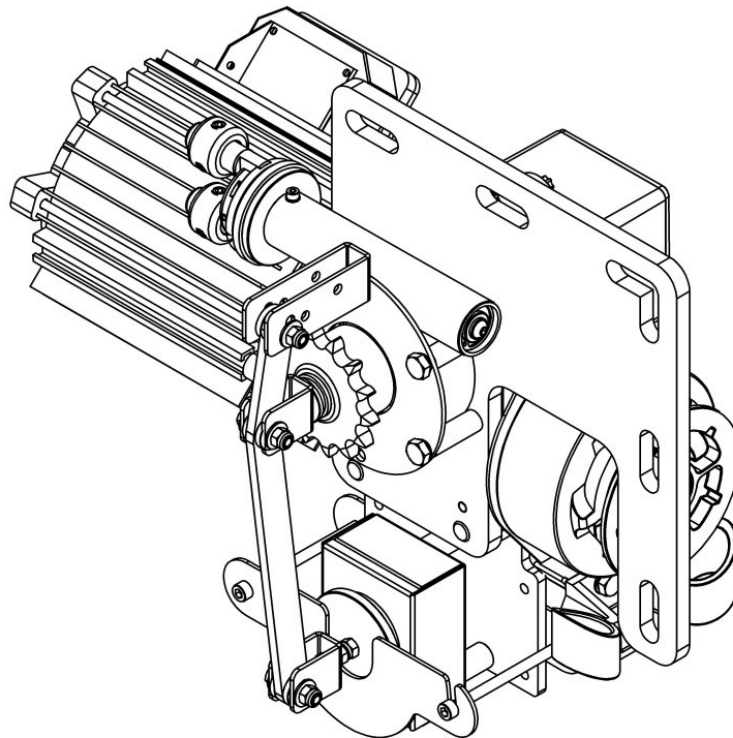

Installation and Users Manual for Fire Shutter Opener

www.grifco.com.au
www.grifco.co.nz

Chamberlain Australia Pty Ltd
PO Box 1446, Lane Cove
NSW 1595, Australia
Phone toll free 1800 474 326

Chamberlain New Zealand Ltd
PO Box 100-221
North Shore 0745, New Zealand
Phone toll free 0800 653 667

TABLE OF CONTENTS

Safety Instructions	3
Introduction	4
Identifying your Opener	4
Planning	5
Installation	6-11
• Mounting	6-8
• Electrical Connection	9
• Reversing Starters	10
• Limit Switch Connections	11
Setup and Adjustment	11-13
• Limit setup	11
• Fire Shutter release arm	12-13
• Descent Speed adjustment	13
Testing	13
Operation	13
Maintenance	14
Troubleshooting	14
Warranty	15

SAFETY SYMBOL AND SIGNAL WORD REVIEW

Safety symbol and signal word review

This commercial door opener has been designed and tested to offer safe service provided it is installed, operated, maintained and tested in strict accordance with the instructions and warnings contained in this manual.



WARNING

Mechanical



WARNING

Electrical



CAUTION

When you see these Safety Symbols and Signal Words on the following pages, they will alert you to the possibility of serious injury or death if you do not comply with the warnings that accompany them. The hazard may come from something mechanical or from electric shock.

When you see this Signal Word on the following pages, it will alert you to the possibility of damage to your commercial door and/or the commercial door opener if you do not comply with the cautionary statements that accompany it.

THESE ARE IMPORTANT SAFETY INSTRUCTIONS. FOLLOW ALL INSTRUCTIONS AS INCORRECT INSTALLATION CAN LEAD TO SEVERE INJURY OR DEATH

	Keep commercial door balanced. Sticking or binding doors must be repaired. Commercial doors, door springs, pulleys, brackets and their hardware are under extreme tension and can cause serious personal injury. Do not attempt to loosen, move or adjust them. Call for commercial door service.		Disengage all existing commercial door locks to avoid damage to commercial door. Install the wall control (or any additional push buttons) in a location where the commercial door is visible during operation. Do not allow children to operate push button(s) or remote control(s). Serious personal injury from a closing commercial door may result from misuse of the opener.
	Do not wear rings, watches or loose clothing while installing or servicing a commercial door opener.		Permanently fasten all supplied labels adjacent to the wall control as a convenient reference and reminder of safe operating procedures.
	To avoid serious personal injury from entanglement, remove all ropes connected to the commercial door before installing the door opener.		Activate opener only when the door is in full view, free of obstructions and opener is properly adjusted. No one should enter or leave the building while the door is in motion.
	Installation and wiring must be in compliance with your local building and electrical codes. Connect the power supply cord only to properly earthed mains.		An electrician must disconnect electric power to the commercial door opener before making repairs or removing covers.
	Moisture and water can destroy the electronic components. Make sure under all circumstances that water moisture or storage moisture cannot penetrate the electronics. The same applies for openings and cable entries.		If the supply cord is damaged, it must be replaced by the manufacturer or its service agent or a similarly qualified person in order to avoid a hazard. A disconnection device incorporated in the fixed wiring must be provided in accordance with the wiring rules of the country in which it is installed.
	After the installation a final test of the full function of the system and the full function of the safety devices must be done.		The actuating member of a biased-off switch is to be located within direct sight of the door but away from moving parts. Unless it is key operated, it is to be installed at a minimum height of 1500mm and not accessible to the public.
	When operating a biased-off switch, make sure that other persons are kept away.		Make sure that people who install, maintain or operate the door follow these instructions. Keep these instructions in a safe place so that you can refer to them quickly when you need to.
	The opener cannot be used with a driven part incorporating a wicket door (unless the opener cannot be operated with the wicket door open).		If the opener is installed at a height less than 2.5 metres from floor level or any other level from which the unit can be accessed (eg mezzanine) the installer is responsible to fit guards to the opener to prevent access to the chain drive.
	Ensure that entrapment between the driven part and the surrounding fixed parts due to the opening movement of the driven part is avoided		This appliance is not intended for use by persons (including children) with reduced physical, sensory or mental capabilities, or lack of experience and knowledge, unless they have been given supervision or instruction concerning use of the appliance by a person responsible for their safety. Children should be supervised to ensure that they do not play with the appliance.
	Motor may become hot during operation. Appropriate clearance and/or shielding should be supplied by the installer to ensure any cabling, wiring and/or other items cannot come in contact with the motor. If temperature rise exceeds 50°C all fixed wiring insulation must be protected, for example, by insulating sleeving having an appropriate temperature rating.		Use the commercial door opener for its intended purpose. eDrive +2.0 openers are designed for operating spring balanced roller shutters, spring balanced roller doors and counterweighted bi-fold and vertical lift doors.



WARNING: Important safety instructions. It is important for the safety of persons to follow all instructions. **SAVE** these instructions.

INTRODUCTION

Congratulations on your purchase of the Grifco™ Fire Shutter opener unit. For more than 50 years, we have been producing industrial mechanical openers that are well known for their proven reliability & robust design.

The Grifco Controlled Descent Mechanism has been developed to allow the safe emergency closing of fire shutters. The system allows efficient operation of the shutter during normal circumstances. If a fire is detected the linkage connected to the system's release arm will break, the shutter will then automatically descend to the ground under its own weight. The shutter lowers safely since its speed is limited by the controlled descent mechanism. This system eliminates the danger associated with a free-falling shutter.

IMPORTANT:

The 58017FFR-480 and 59017FFL-480 must use the GLMe2N-480 (or GLMe2N-480-MCB) as a controller.

The standard Reversing Starter is NOT compatible with the 480V variation opener.

IDENTIFYING YOUR OPENER

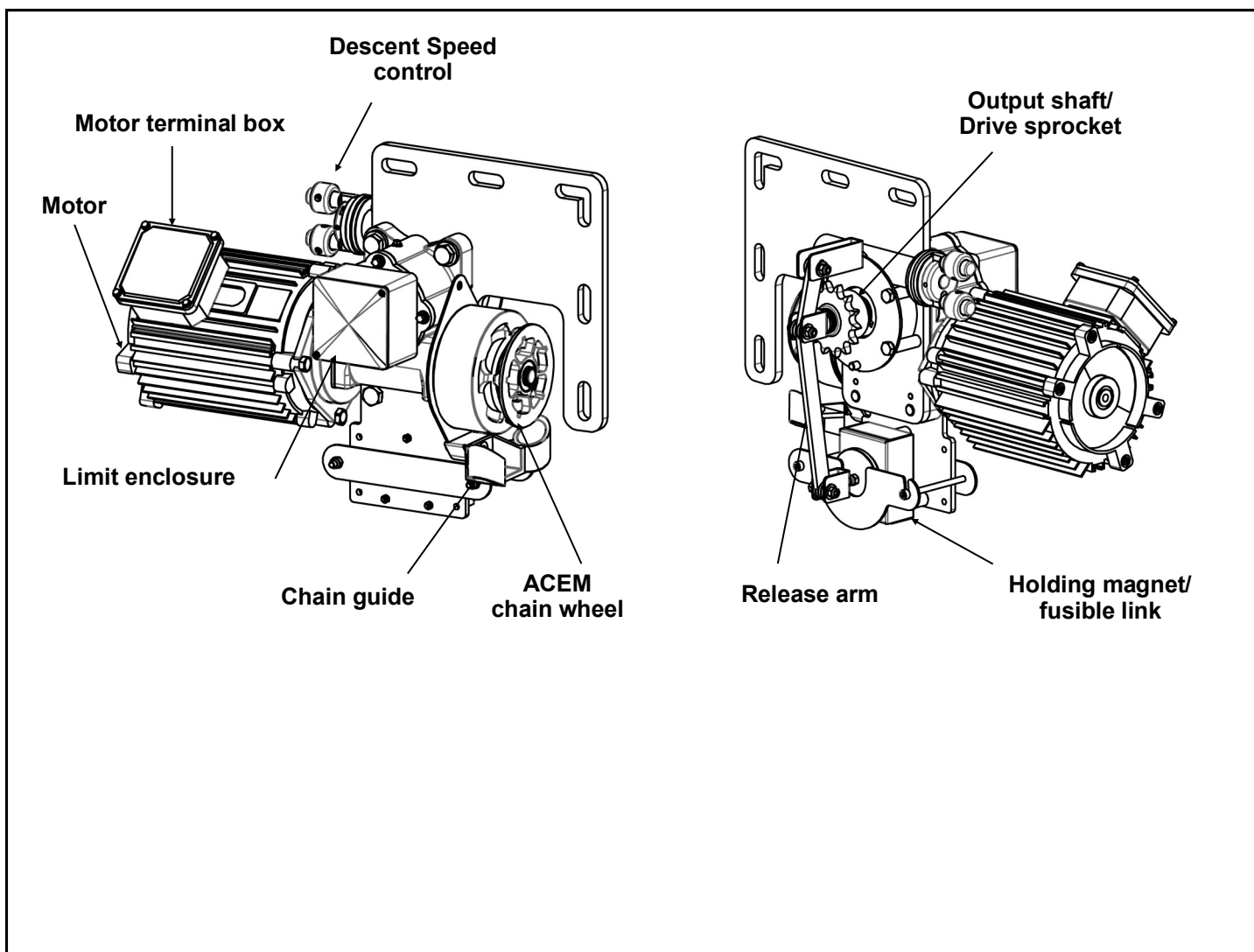

WARNING

Please remove any locks fitted to the door before operation in order to prevent damage to the door.



WARNING

It is important to make sure the door always runs smoothly. Doors which stick or jam must be repaired immediately. Employ a qualified technician to repair the door, never attempt to repair it yourself.

PLANNING

Identify the type and dimensions of your commercial door. A survey of the application is recommended to see if any of the requirements below are not applicable with your installation.

Based on “standard shutter”:

- The shutter is correctly spring balanced
- The shutter has $\leq 1.0\text{mm} \times \geq 100\text{mm}$ slats
- The shutter has no wind-locks
- A $\geq 4:1$ sprocket ratio is used

If any conditions above are not met, some consideration should be given to increasing the sprocket ratio, or opener size. The opener should be installed on the correct side of the commercial door. Consider an In-board mounting kit (P.No IBMK) if there is insufficient side room. Select the side that meets the requirements listed below.

- Must have minimum distance of 15mm between mounting plate and door drum sprocket
 - Must have minimum distance of 200mm between limit housing and imposing structure
 - Must have minimum clearance of 200mm from the terminal box
-
- Before installing the opener, check that the commercial door is in good mechanical condition, correctly balanced and open & closes properly.

BOTTOM RAIL WEIGHT AND/OR REVERSE SPRINGING

To provide the shutter with a greater initial closing force, particularly when fully open, the bottom rail should be made heavier. This can be achieved by attaching approximately 5kg of steel flat bar to the upper side of the bottom rail. An alternative or additional method to ensure the shutter will descend when released is to slightly reverse spring the shutter at its fully open position. This will give the shutter a bias towards closing when it is in its fully open position.

NOTE: The shutter must have radial ball or roller bearings on the shutter axle.

THE RELEASE ARM

The release arm may point in one of the six directions allowed by the six bolts on the plate upon which it is mounted. This is to allow the fusible linkage to be attached in the arrangement most convenient to you. To change the direction of the arm, remove the bolt that attaches the bottom end of the arm to the u-bracket. Tilt the arm about the u-bracket that is connected to the output shaft this will allow access to the bottom u-bracket. The fixed u-bracket may be removed using a spanner on its outside. Remove the bolt from the plate in the position that you wish to fit the u-bracket, screw the u-bracket into this hole. Fit the spare bolt to the hole where the u-bracket was. Refit the arm into the u-bracket using the nut, bolt and washers that were previously removed.

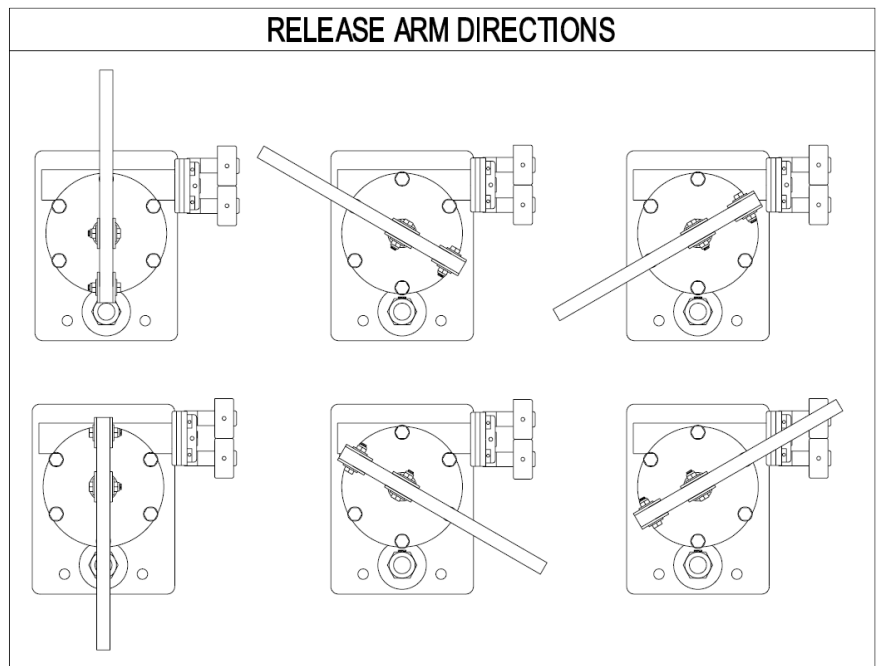

CAUTION

The roller shutter guides must be fitted with mechanical stops that prevent the bottom rail from passing through in the opening direction. The opener should stall if driving into the mechanical stops.

INSTALLATION

Mounting the Unit

The Fire Shutter is typically flag mounted below the door drum so that the opener shaft points toward the door opening and lies beneath the sprocket of the door drum. For mounting you will need to either secure the opener to the roller shutter head plate with prepared holes or slots, or use a mounting plate that will need fixing via a wall angle or similar existing fixture.

Note: THE FIRE SHUTTER IS NOT DESIGNED TO BE INSTALLED UPSIDE DOWN.
THE CHAIN GUIDE MUST NOT BE REPOSITIONED.

When assessing and selecting an appropriate mounting location, the following considerations should be made:

The unit must be mounted accurately so that the drive sprocket lines up with the shutter platewheel. There is only a small allowance for adjustment of the drive sprocket position on the output shaft. Fit the correct length of drive chain around the drive sprocket and platewheel.

MOUNTING POSITIONS FOR LEFT-HAND AND RIGHT-HAND OPERATORS STANDARD AND INBOARD MOUNT

THE DIAGRAMS GIVEN BELOW ARE THOSE WHICH WOULD BE SEEN
WHEN STANDING INSIDE THE DOORWAY LOOKING OUT.

IN THE DIAGRAMS BELOW, THE RELEASE ARM IS SHOWN IN ITS DISENGAGED POSITION

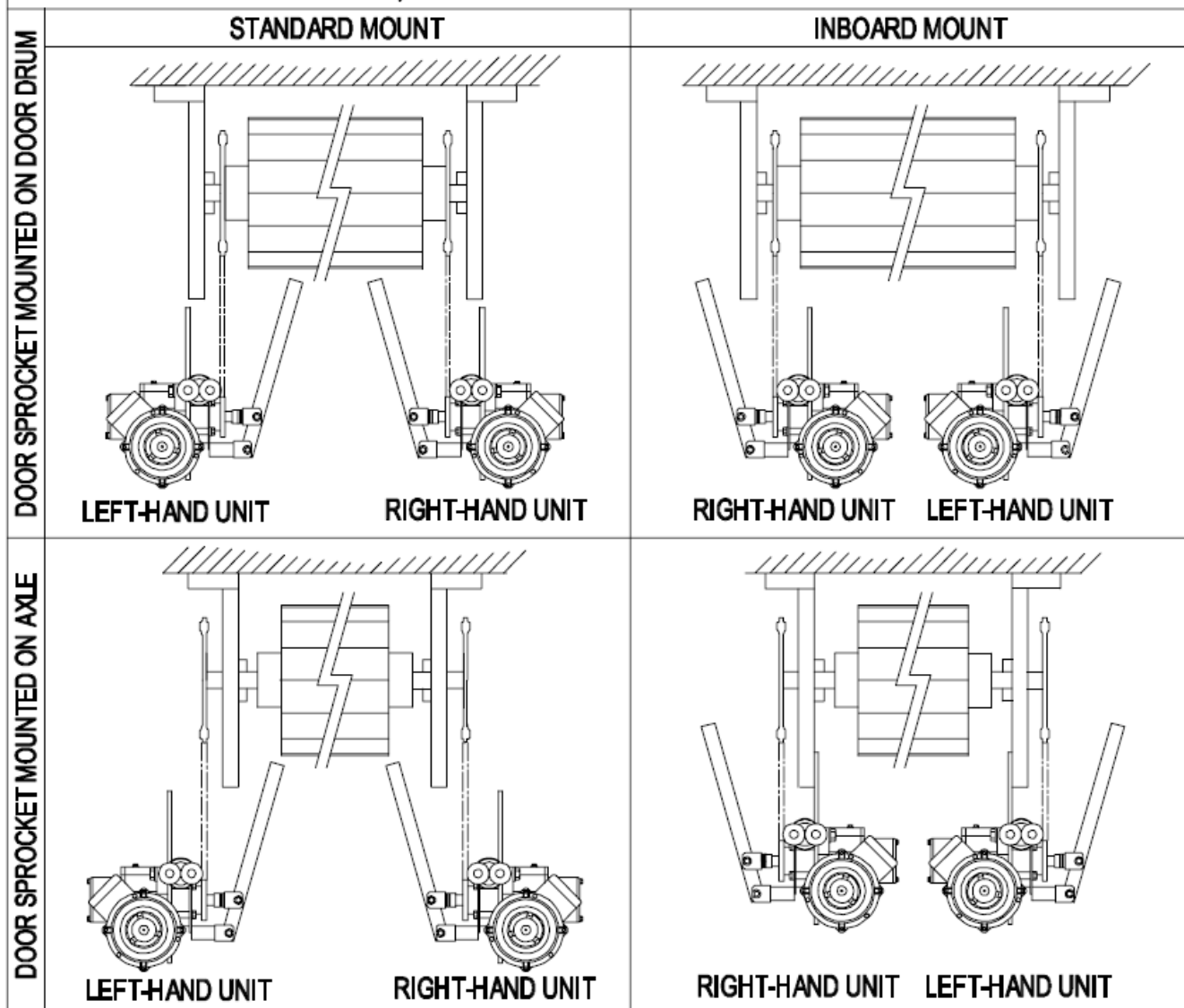

INSTALLATION

Mounting the Unit (continued)

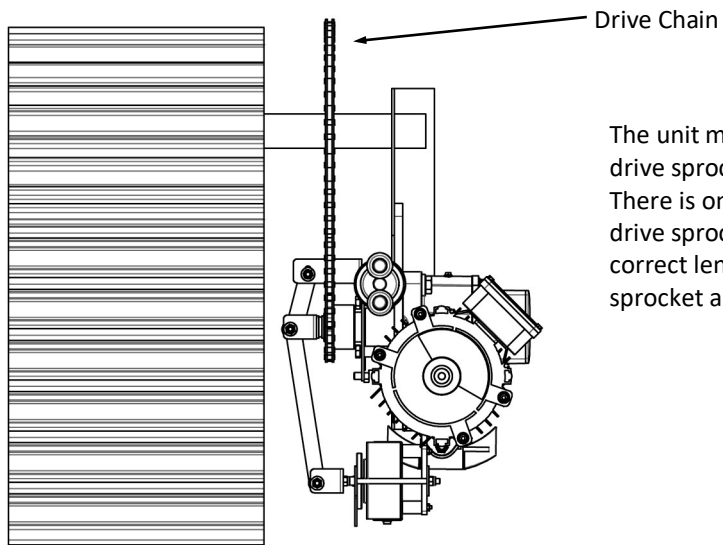

The unit must be mounted accurately so that the drive sprocket lines up with the shutter platewheel. There is only a small allowance for adjustment of the drive sprocket position on the output shaft. Fit the correct length of drive chain around the drive sprocket and platewheel.

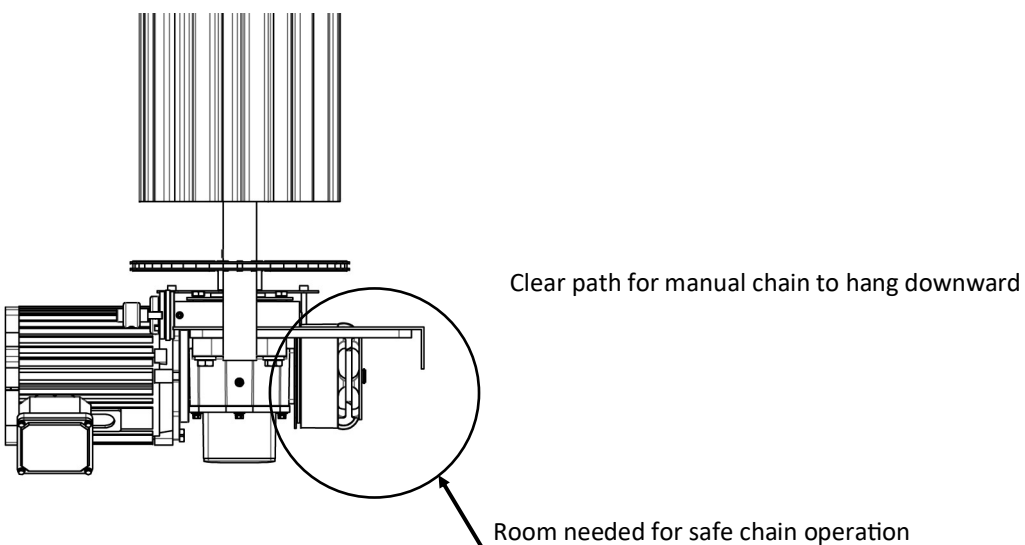
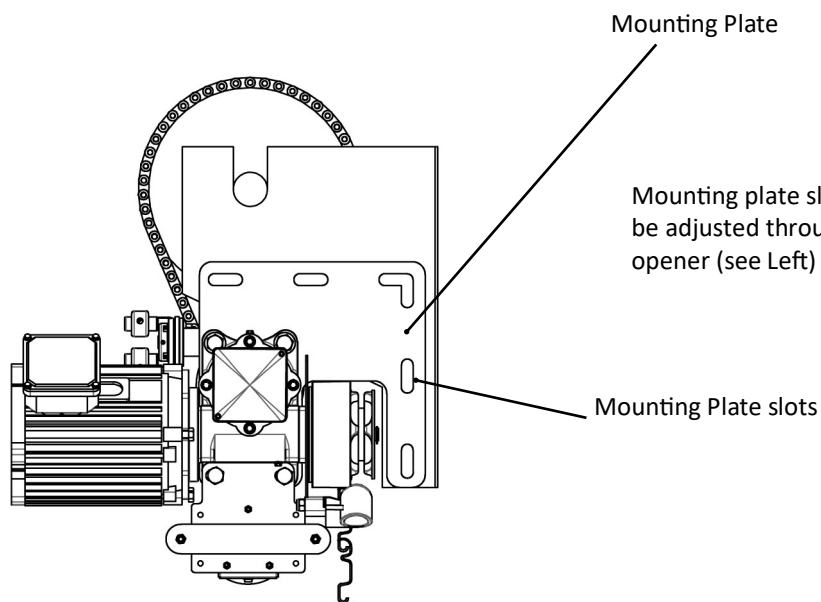

INSTALLATION

Mounting the Unit (continued)

Side room to imposing structures (see right)

Note: The Fire Shutter limit housing requires adequate clearance to allow setting of limit cams during installation. 150mm is the minimum recommended clearance between wall and lid. Where there is insufficient side room, consider using the opposite hand opener and mount inboard with a Grifco™ Inboard Mounting Kit, Part No. IBMK.

The drive sprocket must be aligned with the door sprocket, and locked using 2 x M8 hi-tensile grub screws tightened to min 20Nm. Grub screws must be set between 90° and 120° apart, with one grub screw lying over the drive key.

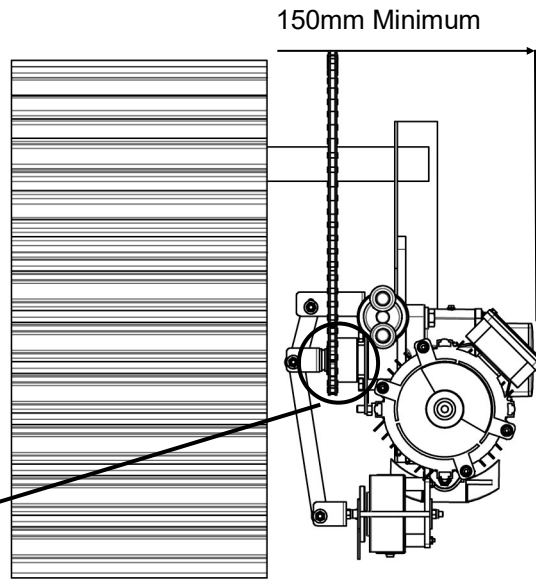

Chain tension should be set between 10-20kgs, ensuring both sides of the linkage are taught. Where practicable, use the weight of the opener as a preload, then tighten mounting bolts. M12 fasteners should be tightened between 80-90Nm.

Ensure the mounting position allows the hand chain to hang free of obstructions (see right)

Ensure hand chain is not twisted when making the join!

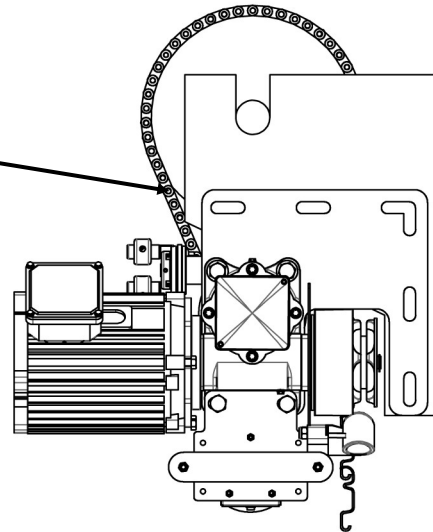

Automatic Chain Engagement Mechanism (ACEM)

The patented ACEM features allows the use of the hand chain in the event of a power failure. Simply pull on the hand chain in either direction to operate the door manually.

Warning! Ensure power is isolated when using this feature.

The ACEM label (see right) must be fixed in close proximity to the controller e.g. on the door track.



INSTALLATION

CAUTION

When Securing the Fire Shutter Opener with the 4 x M12 x 40mm long fasteners (based on a 10mm mounting plate) and spring washers provided, it is critical to ensure that the applied torque is between 80-90Nm. When mounting through thicker sections, ensure a minimum of 30mm of screw thread is engaged with the female thread. Use of incorrect fasteners or torque may cause serious product damage and/or personal injury. When fixing through a slotted plate, ensure that the slots are no wider than 13mm as a spring washer may not be adequate in outside diameter to support the hexagon head.

CAUTION

The Fire Shutter Opener **must**:

- be connected via a device that is capable of being locked for maintenance
- be connected via a suitable circuit breaker that disconnects all live conductors
- be connected in accordance with the wiring rules of the country in which it is installed
- not have control enclosures left open for extended periods (excess dust will void warranty)
- Run all cable through non-flexible conduit and use appropriate conduit entries

Electrical Connections

Motor connections

MODELS: Three phase 3 wire

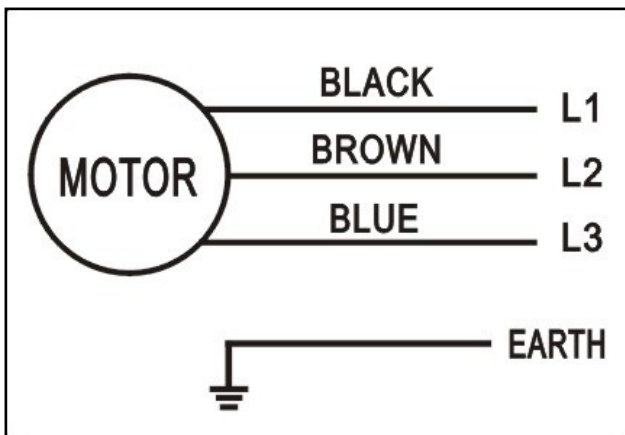

MODELS: Single phase 4 wire

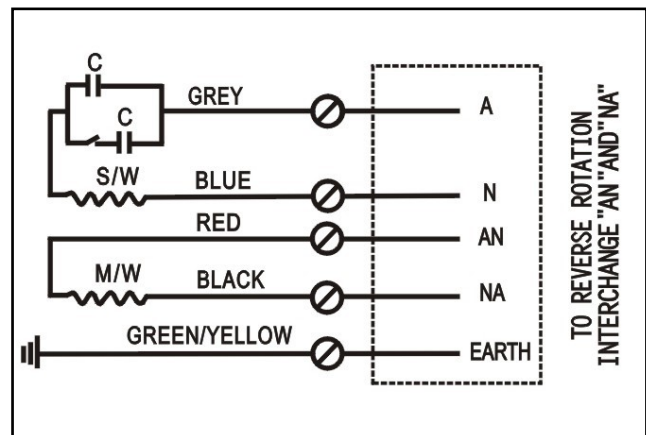

MODELS: Single phase 3 wire

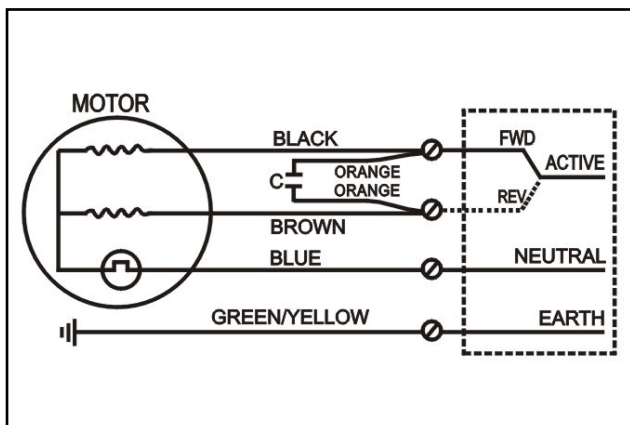

MODELS: To suit special 3ph openers

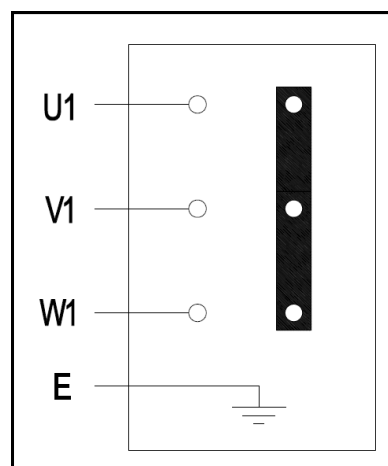

INSTALLATION**REVERSING STARTERS AND OVERLOADS**

3 Phase	RG374-LB3E007 415V Three \emptyset Motor, 240V Control Circuit, 2.3A - 3.2A Three \emptyset Amperage Overload RG374-LB3E007-EX 415V Three \emptyset Motor, 240V Control Circuit, 2.3A - 3.2A Three \emptyset Amperage Overload
3 Phase No-Neutral	RG378-LB3E007 415V Three \emptyset Motor, 240V Control Circuit, 2.3A - 3.2A Three \emptyset Amperage Overload
Single Phase	RG376-LB1E009 240V Single \emptyset Motor, 240V Control Circuit, 4 Wire, 4.5A - 6.3A Single \emptyset Amperage Overload

For reversing starter connection details:
Refer to the diagram included with the control

Electronic Logic Controllers

GLMe2	415V Three \emptyset Motor 240V Single \emptyset 3 wire Motor 240V Single \emptyset 4 wire Motor
GLMe2N	415V Three \emptyset Motor
GLMe2L	415V Three \emptyset Motor 240V Single \emptyset 3 wire Motor 240V Single \emptyset 4 wire Motor
GLMe2NL	415V Three \emptyset Motor

INSTALLATION

Limit Switch Connection

The limit switches are connected to the control gear being used via the NORMALLY CLOSED (N/C) and COMMON (COM) of the microswitch:

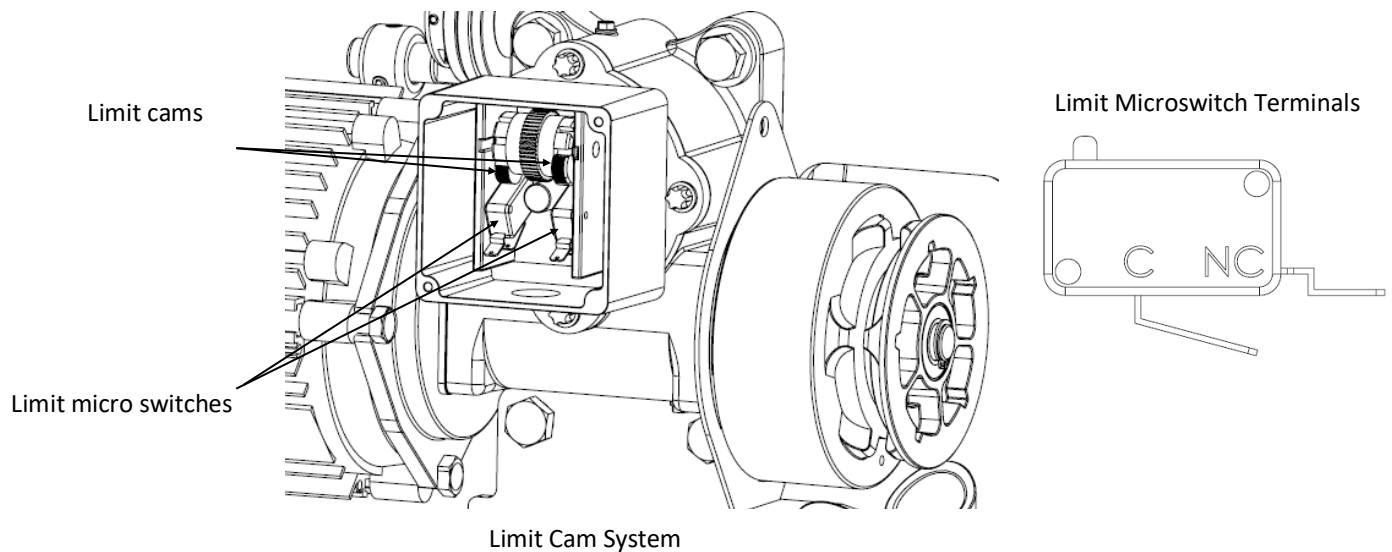

SETUP AND ADJUSTMENT

Limit setting procedure

- ISOLATE MAINS BEFORE SETTING LIMITS
- AVOID CRAMMING WIRES INTO LIMIT ENCLOSURE AS IT MAY AFFECT CAM MOVEMENT

Follow the steps below:

1. Manually position the door in the centre of the opening.
2. Position one cam to depress a switch and the other so that it is well clear of the switch (note which switch it is that you have depressed).

For controls with up and down functions:

- Supply power and activate control in the upward direction.
- If the door travels up, then the limit switch which is engaged by the cam is the CLOSED limit.
- If the door doesn't move it is at the OPEN limit.
- Continue to Step 3 below

For single button controls:

- Supply power and push the button.
- If the door travels up, then the limit switch which is engaged by the cam is the CLOSED limit.
- If the door travels down, then the limit switch which is engaged by the cam is the OPEN limit.
- Continue to Step 3 below

3. Isolate power and adjust the limit cams to depress the switches when the shutter reaches its OPEN and CLOSED positions.
4. Supply power and cycles the door between the OPEN and CLOSED positions. Adjust cam position if necessary.



WARNING

Limits are extremely sensitive, a small cam movement may correspond to a large amount of shutter travel.

SETUP AND ADJUSTMENT

Fire Shutter Mechanism

RELEASE ARM DISENGAGED POSITION

When the release arm has no fusible linkage connected, the spring inside the mechanism will force the arm into its disengaged position. In this position the output shaft is disengaged from the drive sprocket and engaged with the flyweight shaft. This is the position of the arm for controlled descent of the shutter without electrical power.

RELEASE ARM "WAITING TO ENGAGE"

The release arm may only be fully engaged on half of the output shaft rotation. For the other half of its rotation the arm will be held out at a slight angle to the plate. This will be called "waiting to engage". When the release arm is waiting to engage, operating it manually or electrically will cause it to automatically engage.

RELEASE ARM ENGAGED POSITION

In this position the output shaft is engaged with the sprocket and disengaged from the flyweight shaft. This is the position for normal electrical or manual operation of the shutter. To engage the arm, a spring assisted fusible linkage is used. In the engaged position the release arm is parallel to the mounting plate.

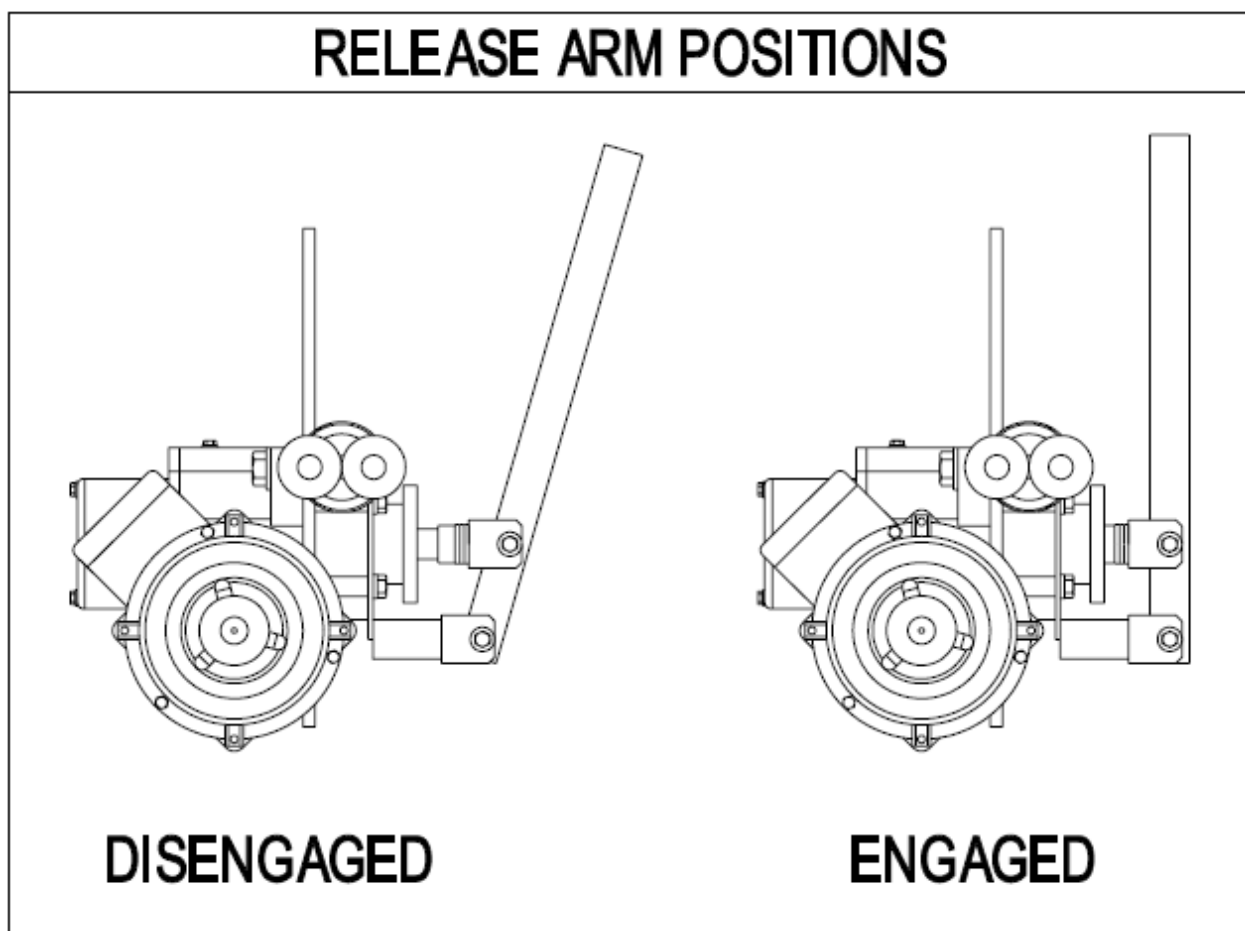

SETUP AND ADJUSTMENT

Fire Shutter Mechanism

RELEASE ARM FUSIBLE LINKAGE TYPES

There are three basic forms of fusible linkages, heat, voltage, and heat and voltage. These systems may be connected in series with a cable.

FUSIBLE LINKAGE CONNECTION

The fusible linkage should be connected in series with a spring so that it engages the release arm. The end of the linkage not connected to the release arm should be fastened to a secure fixed point. The linkage must be arranged so that the force provided to engage the release arm is in a direction close to parallel to the axis of the output shaft.

RELEASE ARM SPRING TENSION

When the release arm is in the engaged position, the spring should be stretched to be at least 250mm in length.

ADJUSTING THE CONTROLLED DESCENT SPEED

The speed at which the shutter falls during controlled descent can be adjusted by moving the governor flyweights. If the flyweights are at their outermost points on their shafts, descent speed will be at its lowest. If they are on their innermost points the descent speed will be at its highest. To move the flyweights, loosen their grub screws with an allen key and slide them into the desired position on their shafts. Tighten the grub screws with the allen key.

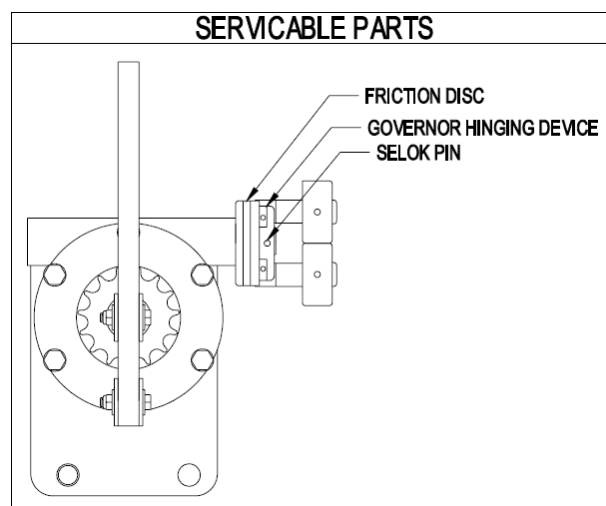
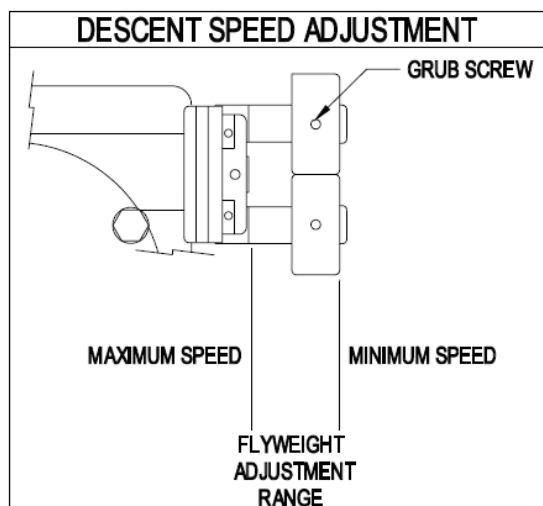

TESTING

To test the system, engage the release arm and lift the shutter 500mm with the hand chain. Then disengage the release arm. The shutter should fall steadily to the ground.

OPERATION

If the operator is fitted to the shutter and has a spring assisted fusible link causing the release arm to engage or be waiting to engage, it is ready for operation. The shutter may now be operated manually or electrically.

If the fusible link breaks due to fire or fire alarm signal, the shutter will undergo controlled descent to the ground. The release arm is now disengaged.

To operate the shutter after controlled descent, the release arm must be re-engaged with a new fusible link.

MAINTENANCE

Testing

The controlled descent device should be tested every six months in most installations. In corrosive or dusty environments, the device should be tested more often.

Friction Disc

Of the operator's moving parts, the only one that could possibly wear is the friction disc. The disc is located on the governor. The disc is 6mm (1/4") thick. If the disc wears so that it is less than 3mm in thickness, it will need to be replaced. (This type of wear should not occur during the lifetime of the product.) To replace the disc, remove the selok pin that fixes the governor-hinging device to the shaft. When the pin is removed, the hinging device and the friction plate may be removed allowing replacement of the friction disc.

Monthly

- Check chain alignment and tension. *Adjust if required*
- Check PE / IR beam/s and bump edge functionality where applicable

Quarterly

- Check tightness of fixing bolts and (sprocket) grub screws. *Adjust if required* * refer page 6
- Check correct electrical operation
- Check manual operation via hand chain
- Lubricate the drive chain
- Lubricate flyweight linkages and the sliding pin when it is extended from the output shaft**
- Anticorrosion spray should be applied to all components to prevent them from deteriorating**
- Check door balance. *Adjust if required*
- Conduct door maintenance in accordance with door manufactures guidelines. This will include door balance

SERVICE MUST BE CARRIED OUT BY A QUALIFIED TECHNICIAN

TROUBLESHOOTING

PROBLEM	Resolution
Shutter will not lift after engaging release arm	Increase spring tension on release arm, or remove slack from cable linkage.
Shutter does not descend when mechanism tested	A) Ensure drive chain is aligned between sprockets. B) Ensure drive chain is not overtightened. C) Ensure sprockets have not been attached so that eccentric rotation results. D) Check for and remove any obstructions from the shutter guides. E) Ensure roller or ball radial thrust bearings have been used on shutter axle. F) Increase the weight on the bottom rail. And/or G) Increase shutter reverse springing. H) Release some of the spring tension from the shutter drum.
Shutter falls back down when operated	Ensure release arm fully engaged.



CAUTION

DO NOT allow anticorrosion spray, grease or any other lubricating product come into contact with the friction disc or friction plates!

NOTES

CHAMBERLAIN LIMITED WARRANTY - Grifco Products

Chamberlain Australia Pty Limited / Chamberlain New Zealand Limited (**Chamberlain**) is committed to manufacturing and supplying high quality goods. As part of this commitment, we seek to provide reliable service and support for our goods and are pleased to provide you, the original purchaser, with this Chamberlain Limited Warranty.

We also provide the following statement as required by the Australian Consumer Law: In Australia, in addition to your rights under this Chamberlain Limited Warranty, our goods come with guarantees that cannot be excluded under the Australian Consumer Law. You are entitled to a replacement or refund for a major failure and for compensation for any other reasonably foreseeable loss or damage. You are also entitled to have the goods repaired or replaced if the goods fail to be of acceptable quality and the failure does not amount to a major failure.

Chamberlain's warranty

Chamberlain warrants to the original purchaser of the Grifco product (**Unit**) that:

- 1 The Unit (excluding the electric motor) is free from defects in materials and workmanship for a period of 24 months from the date of purchase.
- 2 The electric motor is free from defects in materials and workmanship for a period of 12 months from the date of purchase.

During the applicable Chamberlain Warranty period, if you are concerned that the Unit or electric motor may be defective, call our service centre on the toll free number below before removing the Unit and a Chamberlain technician will diagnose the problem. Once the problem has been diagnosed, subject to your rights under the Australian Consumer Law with respect to major failures, Chamberlain will provide you with:

- 1 parts for "do-it-yourself" repairs; or
- 2 shipping instructions for a factory repair or replacement.

If a factory repair or replacement is required, provided the defective part or Unit is returned to Chamberlain well-packaged and in accordance with Chamberlain's shipping instructions, Chamberlain will, subject to your rights under the Australian Consumer Law with respect to major failures:

- 1 in relation to the Unit (excluding the electric motor), repair or, at its option where permissible, replace any defective part or Unit (excluding the electric motor) and return it to you at no cost; and
- 2 in relation to the electric motor, replace the electric motor and return it to you at no cost.

Where the Unit has been installed by an authorised installer, you must call them for prompt on-site service. Chamberlain will furnish replacement parts free of charge through the authorised installer. A service fee for on-site service may apply.

Repairs and replacement parts provided under this Chamberlain Limited Warranty are provided free of charge and are warranted for the remaining portion of the original warranty period.

This Chamberlain Limited Warranty provides benefits which are in addition to your other rights and remedies as a consumer.

Exclusions

If our service centre determines that a warranty claim has been made in respect of a failure or defect arising under or out of any exclusion detailed below such that the claim is not covered under this Chamberlain Limited Warranty, we may, subject to your other rights and remedies as a consumer, charge you a fee to repair, replace and/or return the Unit to you.

This Chamberlain Limited Warranty does not cover any failure of, or defect in, the Unit due to:

- 1 non-compliance with the instructions regarding installation, operation, maintenance and testing of the Unit or of any product with which the Unit is used;
- 2 any attempt by a person other than an authorised installer to change settings, repair, dismantle, reinstall or move the Unit to another location once it has been installed;
- 3 tampering, neglect, abuse, wear and tear, accident, electrical storm, excessive use or conditions other than normal commercial use;
- 4 use of the Unit in conjunction with controls which have not been supplied, or pre-approved, by Chamberlain;
- 5 problems with, or relating to, the commercial door or commercial door hardware, including but not limited to the door springs, door rollers, door alignment, hinges, guides, slats and drums; or
- 6 problems caused by electrical faults.

If this Chamberlain Limited Warranty does not apply, you may have rights available to you under the Australian Consumer Law.

Liability – Australia only

Except as set out in the Australian Consumer Law (being Schedule 2 of the *Competition and Consumer Act 2010*) (as amended, consolidated or replaced):

- 1 all other guarantees, warranties and representations in relation to the Unit or its supply are excluded to the extent that Chamberlain can lawfully exclude them; and
- 2 under no circumstances will Chamberlain be liable for consequential, incidental or special damages arising in connection with the use, or inability to use, the Unit, other than those which were reasonably foreseeable as liable to result from the failure.

Liability – New Zealand only

Except as set out in the *Fair Trading Act 1986* and the *Consumer Guarantees Act 1993* (as amended, consolidated or replaced):

- 1 all other guarantees, warranties and representations in relation to the Unit or its supply are excluded to the extent that Chamberlain can lawfully exclude them; and
- 2 under no circumstances will Chamberlain be liable for consequential, incidental or special damages arising in connection with the use, or inability to use, the Unit, other than those which were reasonably foreseeable as liable to result from the failure.

Note

We request that you retain your sales docket or invoice as proof-of-purchase and attach it to this manual to enable you to establish the date of purchase in the unlikely event of a warranty service being required. Chamberlain reserves the right to change the design and specifications of the Unit without prior notification. Some features or accessories of the Unit may not be available in certain markets or areas. Please check with your distributor.

Chamberlain service centre contact details

Australia

Phone toll free 1800 474 326
Fax toll free 1800 888 121
Unit 1, 75 Epping Road
North Ryde, NSW 2113

Email

customerservice@chamberlainanz.com

New Zealand

Auckland phone 09 477 2823
Phone toll free 0800 653 667
Fax toll free 0800 653 663

Websites

www.grifco.com.au or www.grifco.co.nz