

CHAMBERLAIN®

GRIFCO

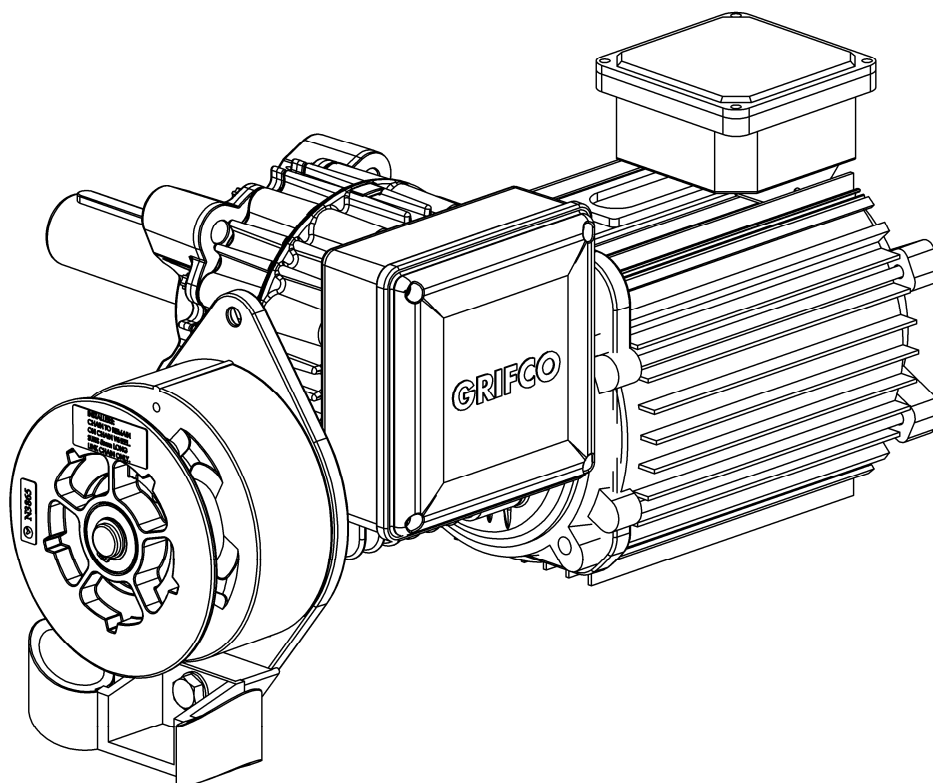

Installation and users
manual for mDrive
industrial door opener

Australia
Phone 02 4323 3877
Phone toll free 1800 GRIFCO
or 1800 474 326
Fax 02 4323 3882

New Zealand
Phone 09 477 2823
Phone toll free 0800 653 667
Fax 09 478 4294

www.chamberlainanz.com

Safety symbol and signal word review

This commercial door opener has been designed and tested to offer safe service provided it is installed, operated, maintained and tested in strict accordance with the instructions and warnings contained in this manual.



WARNING

Mechanical



WARNING

Electrical



CAUTION

When you see these Safety Symbols and Signal Words on the following pages, they will alert you to the possibility of serious injury or death if you do not comply with the warnings that accompany them. The hazard may come from something mechanical or from electric shock.

When you see this Signal Word on the following pages, it will alert you to the possibility of damage to your commercial door and/or the commercial door opener if you do not comply with the cautionary statements that accompany it.

START BY READING THESE IMPORTANT SAFETY RULES



Keep commercial door balanced. Sticking or binding doors must be repaired. Commercial doors, door springs, cables, pulleys, brackets and their hardware are under extreme tension and can cause serious personal injury. **Do not attempt to loosen, move or adjust them.** Call for commercial door service.



Do not wear rings, watches or loose clothing while installing or servicing a commercial door opener.



To avoid serious personal injury from entanglement, **remove all ropes connected to the commercial door** before installing the door opener.



Installation and wiring must be in compliance with your local building and electrical codes. **Connect the power supply cord only to properly earthed mains.**



After the installation, a final test of the full function of the system and the full function of the safety devices must be done.



Disengage all existing commercial door locks to avoid damage to commercial door.

Install the wall control (or any additional push buttons) **in a location where the commercial door is visible during operation. Do not allow children to operate push button(s) or remote control(s).** Serious personal injury from a closing commercial door may result from misuse of the opener.



Activate opener only when the door is in full view, free of obstructions and opener is properly adjusted. No one should enter or leave the building while the door is in motion.



An electrician must disconnect electric power to the commercial door opener before making repairs or removing covers.



Make sure that people who install, maintain or operate the door follow these instructions. Keep these instructions in a safe place so that you can refer to them quickly when you need to.

TABLE OF CONTENTS

Safety rules	2	Connection	9
Introduction	3	Limit setting procedure	9
Identifying your Opener	3	General Maintenance	10
Planning	4	Notes	11
Installation	5-7	Warranty	12
Mounting the unit	5-6		
Motor connection	7		
Reversing starters and overloads	8		
Limit switch connection and setting	9		

INTRODUCTION

Congratulations on your purchase of the Grifco™ mDrive opener unit. For more than 50 years, we have been producing industrial mechanical openers that are well known for their proven reliability & robust design.

IDENTIFYING YOUR OPENER

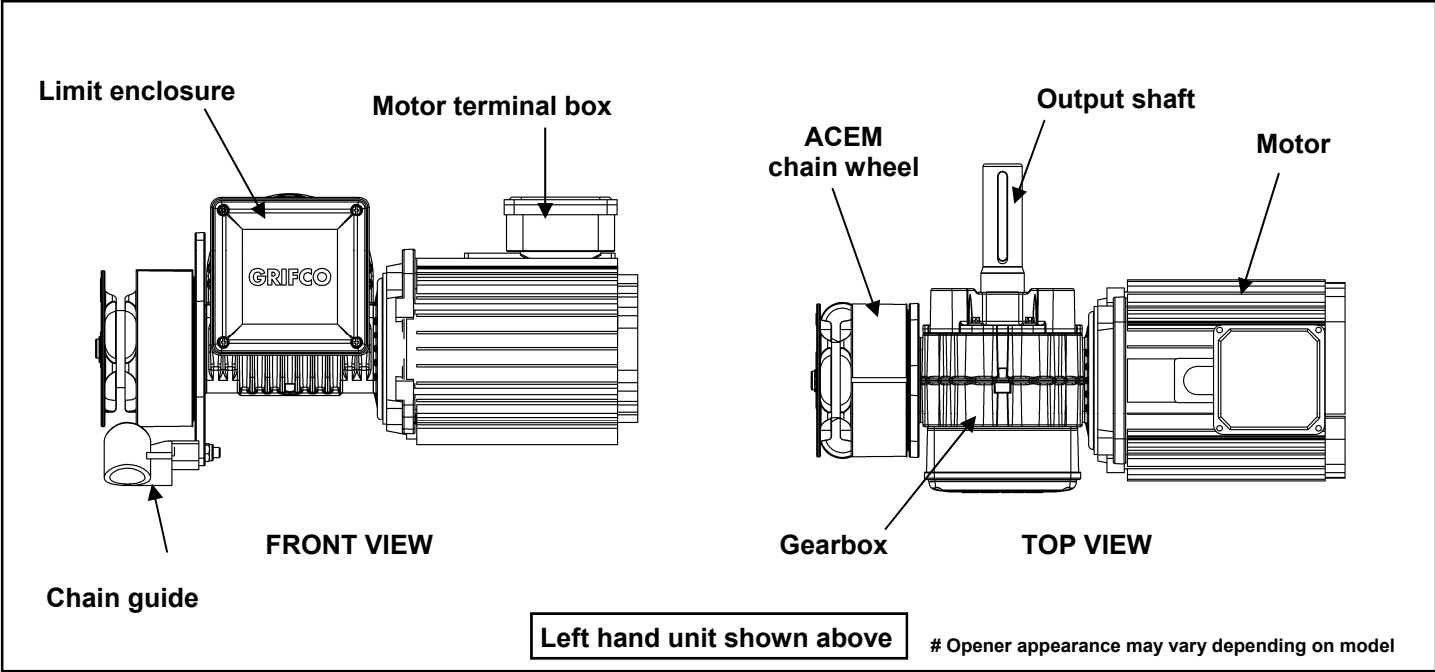

⚠ WARNING

Please remove any locks fitted to the door before operation in order to prevent damage to the door.

⚠ WARNING

It is important to make sure the door always runs smoothly. Doors which stick or jam must be repaired immediately. Employ a qualified technician to repair the door, never attempt to repair it yourself.

PLANNING

Identify the type and dimensions of your commercial door. A survey of the application is recommended to see if any of the requirements below are not applicable with your installation.

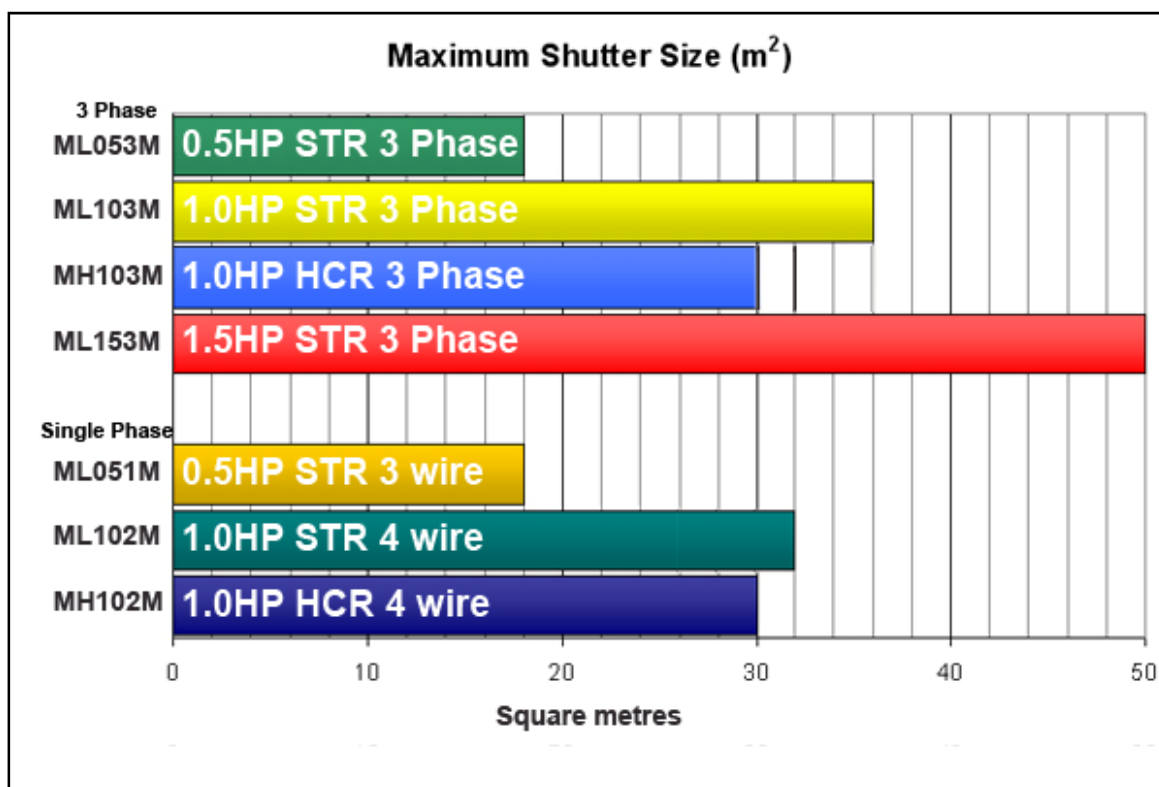

Based on “standard shutter”:

- The shutter is correctly spring balanced
- The shutter has $\leq 1.0\text{mm}$ x $\geq 100\text{mm}$ slats
- The shutter has no wind-locks
- A $\geq 4:1$ sprocket ratio is used

If any conditions above are not met, some consideration should be given to increasing the sprocket ratio, or opener size. The opener should be installed on the correct side of the commercial door. Consider an In-board mounting kit (P.No IBMK) if there is insufficient side room. Select the side that meets the requirements listed below.

- Must have minimum distance of 15mm between mounting plate and door drum sprocket
- Must have minimum distance of 200mm between limit housing and imposing structure
- Must have minimum clearance of 200mm from the terminal box
- Before installing the opener, check that the commercial door is in good mechanical condition, correctly balanced and open & closes properly.



CAUTION

The roller shutter guides must be fitted with mechanical stops that prevent the bottom rail from passing through in the opening direction. The opener should stall if driving into the mechanical stops.

INSTALLATION SECTION

Mounting the Unit

The mDrive is typically flag mounted below the door drum so that the opener shaft points toward the door opening and lies beneath the sprocket of the door drum. For mounting you will need to either secure the opener to the roller shutter head plate with prepared holes or slots, or use a mounting plate that will need fixing via a wall angle or similar existing fixture.

Note: THE mDrive IS NOT DESIGNED TO BE INSTALLED UPSIDE DOWN.
THE CHAIN GUIDE MUST NOT BE REPOSITIONED.

When assessing and selecting an appropriate mounting location, the following considerations should be made:

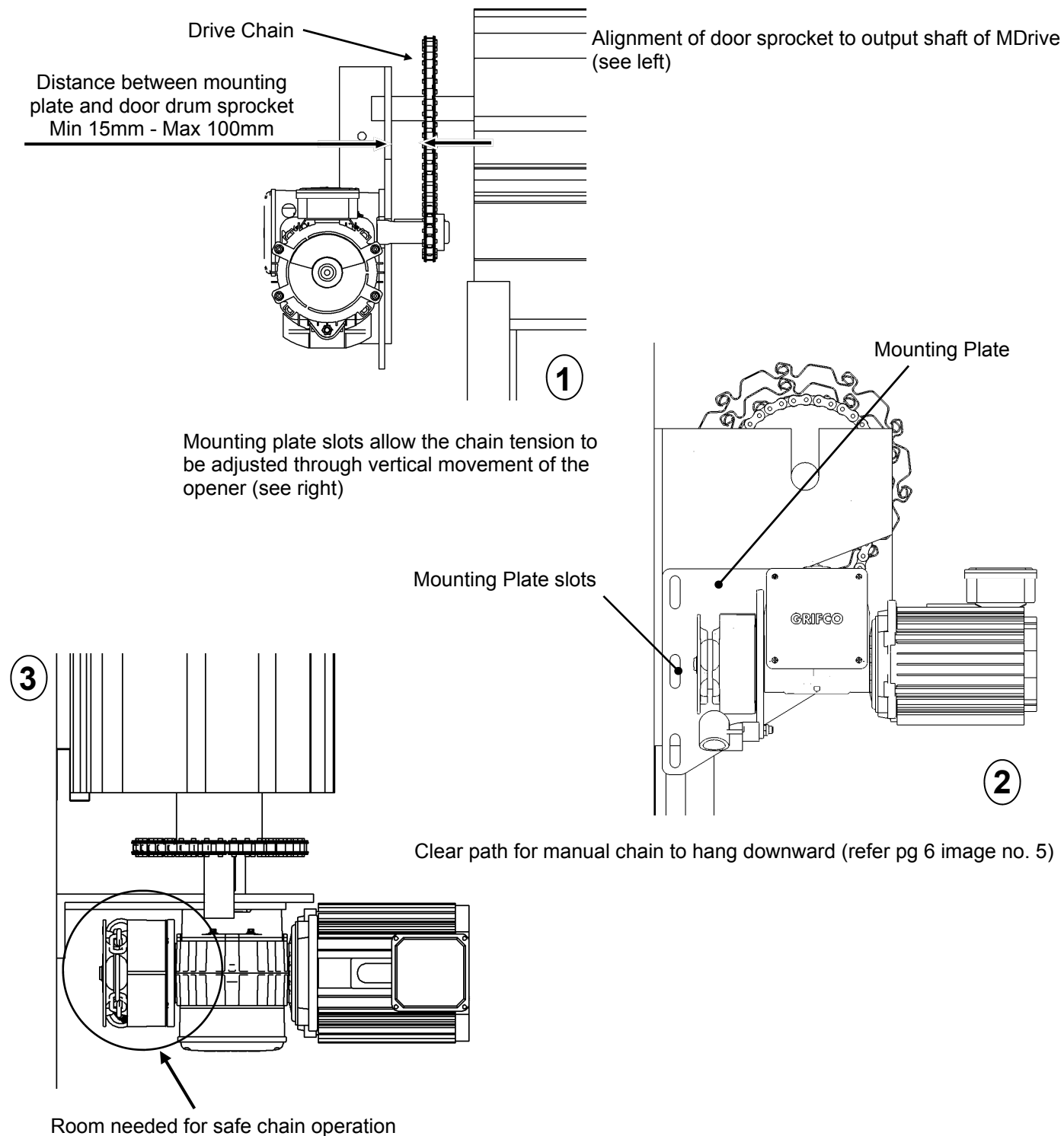

Mounting the Unit (continued)

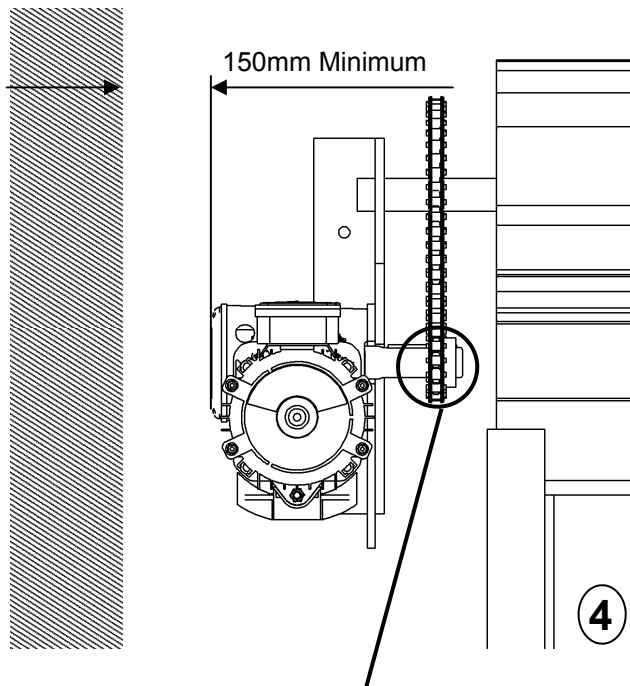

Side room to imposing structures (see left)

Note: The mDrive limit housing requires adequate clearance to allow setting of limit cams during installation. 150mm is the minimum recommended clearance between wall and lid. Where there is insufficient side room, consider using the opposite hand opener and mount in-board with a Grifco™ Inboard Mounting Kit, Part No. IBMK.

The drive sprocket must be aligned with the door sprocket, and locked using 2 x M8 hi-tensile grub screws tightened to min 20Nm. Grub screws must be set between 90° and 120° apart, with one grub screw lying over the drive key.

Chain tension should be set between 10-20kgs, ensuring both sides of the linkage are taught. Where practicable, use the weight of the opener as a preload, then tighten mounting bolts. M12 fasteners should be tightened between 80-90Nm.

Ensure the mounting position allows the hand chain to hang free of obstructions (see right)

Ensure hand chain is not twisted when making the join!

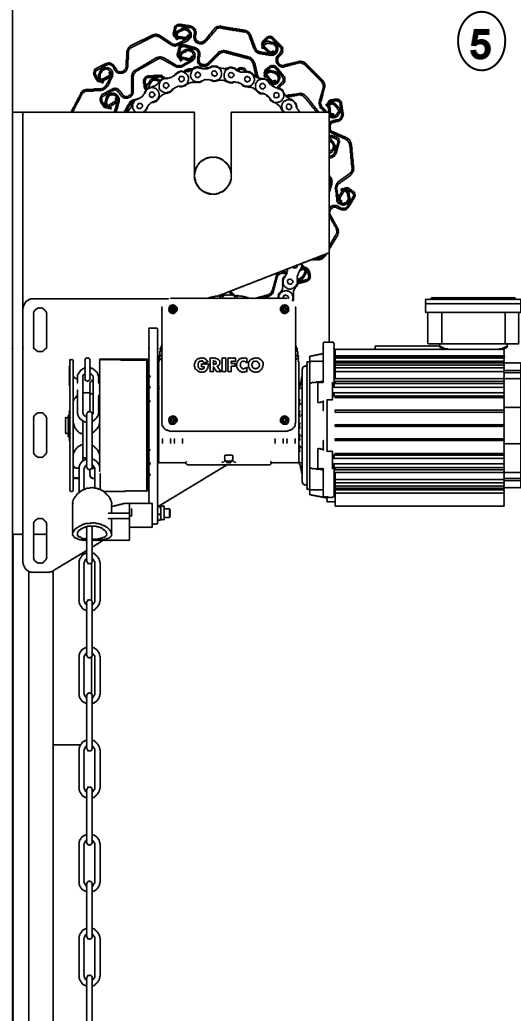

CAUTION

When Securing the mDrive Opener with the 4 x M12 x 40mm long fasteners (based on a 10mm mounting plate) and spring washers provided, it is critical to ensure that the applied torque is between 80-90Nm. When mounting through thicker sections, ensure a minimum of 30mm of screw thread is engaged with the female thread. Use of incorrect fasteners or torque may cause serious product damage and/or personal injury. When fixing through a slotted plate, ensure that the slots are no wider than 13mm as a spring washer may not be adequate in outside diameter to support the hexagon head.

⚠ CAUTION

The mDrive Opener **must**:

- be connected via a device that is capable of being locked for maintenance
- be connected via a suitable circuit breaker that disconnects all live conductors
- be connected in accordance with the wiring rules of the country in which it is installed
- not have control enclosures left open for extended periods (excess dust will void warranty)

Motor connections

MODELS: Three phase 3 wire

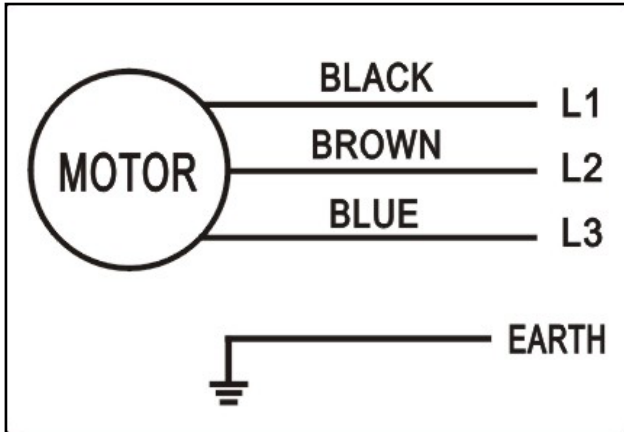

MODELS: Single phase 4 wire

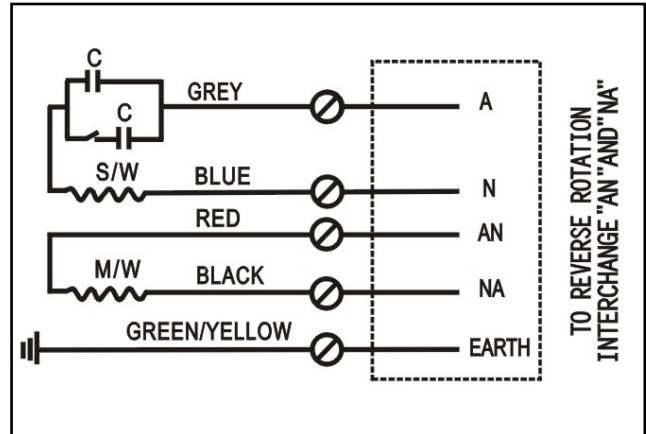

MODELS: Single phase 3 wire

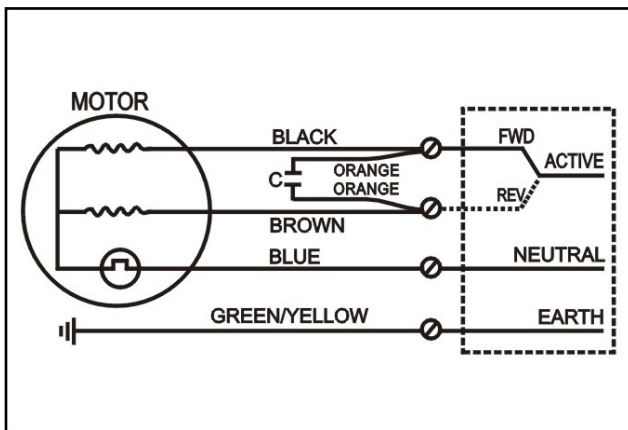

MODELS: To suit special 3ph openers

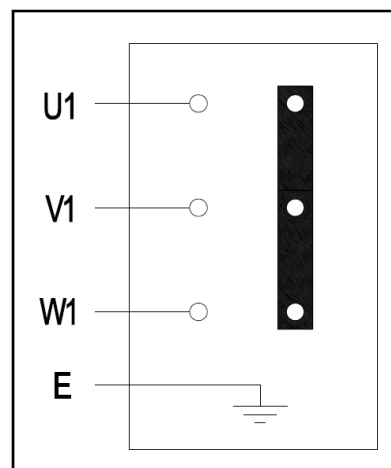

REVERSING STARTERS AND OVERLOADS

Reversing starters:	RB374 - 415V Three Ø Motor, 240V Control Circuit
	RB375 - 240V Single Ø Motor, 240V Control Circuit, 3 Wire
	RB376 - 240V Single Ø Motor, 240V Control Circuit, 4 Wire
	RB378* - 415V Three Ø Motor, 415V Control Circuit
Three phase overloads :	LB3E006 - 1.2 - 1.8A Three Ø Amperage Overload
	LB3E007* - 1.8 - 2.8A Three Ø Amperage Overload
	LB3E008 - 2.8 - 4.0A Three Ø Amperage Overload
	LB3E009 - 4.0 - 6.3A Three Ø Amperage Overload
	LB3E010 - 5.6 - 8.0A Three Ø Amperage Overload
	LB3E012 - 7.0 - 10.0A Three Ø Amperage Overload
Single phase overloads:	LB1E008 - 2.8 - 4.0A Single Ø Amperage Overload
	LB1E009 - 4.0 - 6.3A Single Ø Amperage Overload
	LB1E010 - 5.6 - 8.0A Single Ø Amperage Overload
	LB1E012 - 7.0 - 10.0A Single Ø Amperage Overload

For controls to suit special environment openers contact Chamberlain Australia Pty Ltd

*** If Neutral is unavailable on a 3 Ø installation, the RB378 and corresponding 3 phase overload must be used**

For reversing starter connection details:
Refer to the diagram included with the control



To reduce risk of injury or damage it is strongly recommended that an Infrared safety beam or bump edge be used in conjunction with the opener.

LIMIT SWITCH CONNECTION AND SETTINGS

Connection

The limit switches must be connected to the control gear being used via the NORMALLY CLOSED (N/C) and COMMON (COM) of the microswitch:

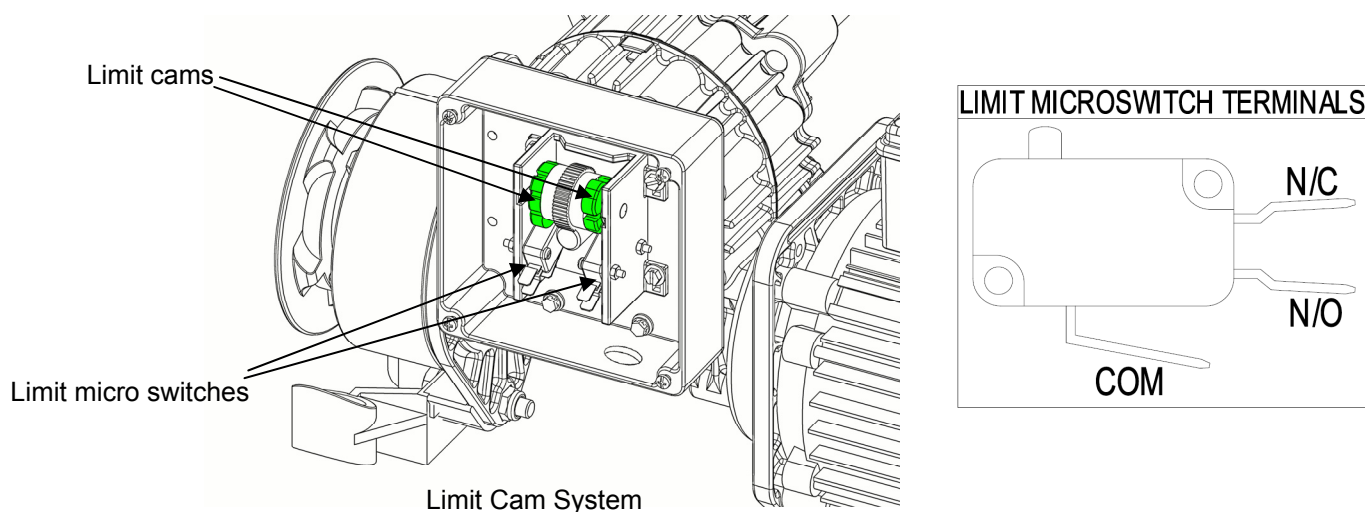

The limit switch mechanism is a worm driven friction held adjustable cam system using two micro switches.



WARNING

Limits are extremely sensitive, a small cam movement may correspond to a large amount of shutter travel.

Limit setting procedure

- ISOLATE MAINS BEFORE SETTING LIMITS
- AVOID CRAMMING WIRES INTO LIMIT ENCLOSURE AS IT MAY AFFECT CAM MOVEMENT

Follow the steps below:

1. Manually position the door in the centre of the opening.
2. Position one cam to depress a switch and the other so that it is well clear of the switch (note which switch it is that you have depressed).

For controls with up and down functions:

- Supply power and activate control in the upward direction.
- If the shutter travels up then the limit switch which is engaged by the cam is the bottom limit.
- If the shutter doesn't move it is the top limit.

For single button controls:

- Supply power and push the button.
- If the shutter moves up, the switch noted above is the bottom limit.
- If it moves down then it is the top limit.

3. Isolate power and adjust the limit cams to depress the switches when the shutter reaches its open and closed Positions.
4. Test the cam positioning and adjust if necessary.

GENERAL MAINTENANCE

Monthly

- Check chain alignment and tension. *Adjust if required **
- Check PE / IR beam/s and bump edge functionality where applicable

Quarterly

- Check tightness of fixing bolts and (sprocket) grub screws. *Adjust if required ** refer page 6
- Check correct electrical operation
- Check manual operation via hand chain
- Lubricate the drive chain *
- Check door balance. *Adjust if required **
- Conduct door maintenance in accordance with door manufactures guidelines. This will include door balance *

* SERVICE MUST BE CARRIED OUT BY A QUALIFIED TECHNICIAN

NOTES

CHAMBERLAIN 24 MONTH LIMITED WARRANTY

(Excluding electric motors)

Chamberlain Australia Pty Limited / Chamberlain New Zealand Limited (**Seller**) warrants to the original purchaser of the Grifco™ product (**Unit**) that it is free from defects in material and/or workmanship for a period of 24 months from the date of first purchase from the Seller.

If, during the limited warranty period, the Unit fails due to defects in materials or workmanship Chamberlain will, provided the defective part or Unit is returned freight and insurance prepaid and well packaged to the nearest Chamberlain office, undertake to repair or, at its option, replace any defective part or Unit and return it to the Buyer at no cost. Repairs and replacement parts are warranted for the remaining portion of the original warranty period.

Limited warranty on electric motors - 12 months

In keeping with the manufacturer's warranty, Chamberlain offer a 12 month warranty on all electric motors from the date of purchase. We will furnish a replacement motor free of charge, if it is found to be defective. Labour costs may apply.

Where the Unit has been installed by an authorised installer, Chamberlain will furnish replacement parts free of charge through the authorised installer. Warranty is based on the electric motor/operator being used in conjunction with controls supplied (or other controls authorised in writing prior to installation) by Chamberlain.

In-warranty service

During the warranty period, if the product appears as though it may be defective, call our technical department before removal of the unit. A Chamberlain technician will diagnose the problem and promptly supply you with the parts for "do-it-yourself" repairs, or provide you with shipping instructions for a factory repair or replacement.

If our service centre determines that a warranty claim has been made in respect of a failure or defect arising under or out of any exclusion set out below, we may charge you a fee to repair and/or return the unit to you.

Exclusions

This warranty does not cover any failure of the Unit due to:

1. non-compliance with the instructions regarding installation, operation, maintenance and testing of the Unit or of any product with which the Unit is used.
2. any attempt to repair, dismantle, reinstall or move the Product to another location once the Product is installed by any person other than an authorised installer.
3. tampering, neglect, abuse, wear and tear, accident, electrical storm (force majeure), excessive use or conditions other than normal commercial use.

This warranty does not cover any problems with, or relating to, the commercial door or door hardware, including but not limited to the door slats, door springs, door drum, door alignment or hinges, any problems caused by electrical faults or labour charges for reinstalling a repaired or replaced Unit.

Liability – Australia only

Under no circumstances shall the Seller be liable for consequential, incidental or special damages arising in connection with the use, or inability to use, the Unit. In no event shall the Seller's liability for damages or injury arising from breach of law or contract or for negligence, exceed the cost of repairing or replacing the Unit or refunding the purchase price of the Unit.

Under Division 2 Part V of the *Trade Practices Act, 1974*, certain warranties and conditions (**Implied Terms**) are implied into contracts for the supply of goods or services if the goods or services are of a kind ordinarily acquired for personal, domestic or household use or consumption. Liability for breach of those Implied Terms cannot be excluded or limited and the limitations and exclusions above do not apply to the Implied Terms.

Except for the Implied Terms and the warranties set out above, the Seller excludes all warranties and conditions implied by statute, at law, in fact or otherwise.

Liability – New Zealand only

Except as set out in the *Fair Trading Act 1986* and the *Consumer Guarantees Act 1993*:

- a) all other guarantees, warranties and representations in relation to the Unit or its supply are excluded to the extent that the Seller can lawfully exclude them; and
- b) under no circumstances shall the Seller be liable for consequential, incidental or special damages arising in connection with the use, or inability to use, the Unit, other than those which were reasonably foreseeable as liable to result from the failure.

Chamberlain reserves the right to change the design and specification without prior notification. Some features or accessories may not be available in certain markets or areas.