



## HDHWF (e/h)

### Universal Manual Fire Door Hoist

'e' – standard hoist

'h' – heavy duty hoist

#### Contents:

Introduction	Page 2
Installation	Page 3
Mounting the unit	Page 3
Release arm disengaged position	Page 4
Release arm engaged position	Page 4
Bottom rail weight and / or reverse springing	Page 4
Fusible linkage connection	Page 5
Release arm spring tension	Page 5
Testing the system	Page 5
Adjusting the controlled descent speed	Page 5
Adjusting the rolling door holding brake	Page 6
Service and maintenance	Page 6
Troubleshooting guide	Page 7
Warranty	Page 8

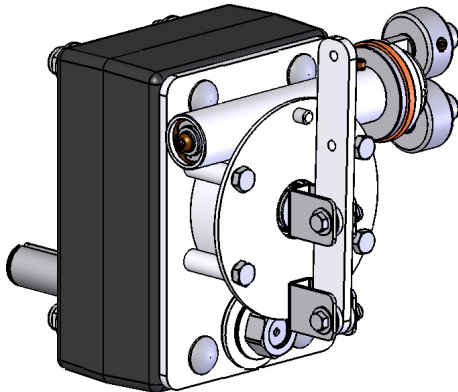
A detailed 3D technical drawing of the HDHWF fire door hoist. The unit is rectangular with a dark grey/black top and a silver-colored metal body. It features various adjustment points, including a large circular dial on the front, a release arm mechanism on the right side, and a mounting bracket with several screws. A cylindrical component is visible on the left side.

## INTRODUCTION

The Grifco Manual Fire Door Hoist has been developed to allow the safe emergency closing of “dead shaft” or “live shaft” rolling fire doors. The system allows manual use of the rolling door during normal circumstances. If a fire is detected, the linkage connected to the hoist release arm will break. The rolling door will then automatically descend to the ground under its own weight. The rolling door lowers safely via the controlled descent mechanism. This system eliminates the danger associated with a free-falling rolling door.

# MANUAL FIRE DOOR HOIST

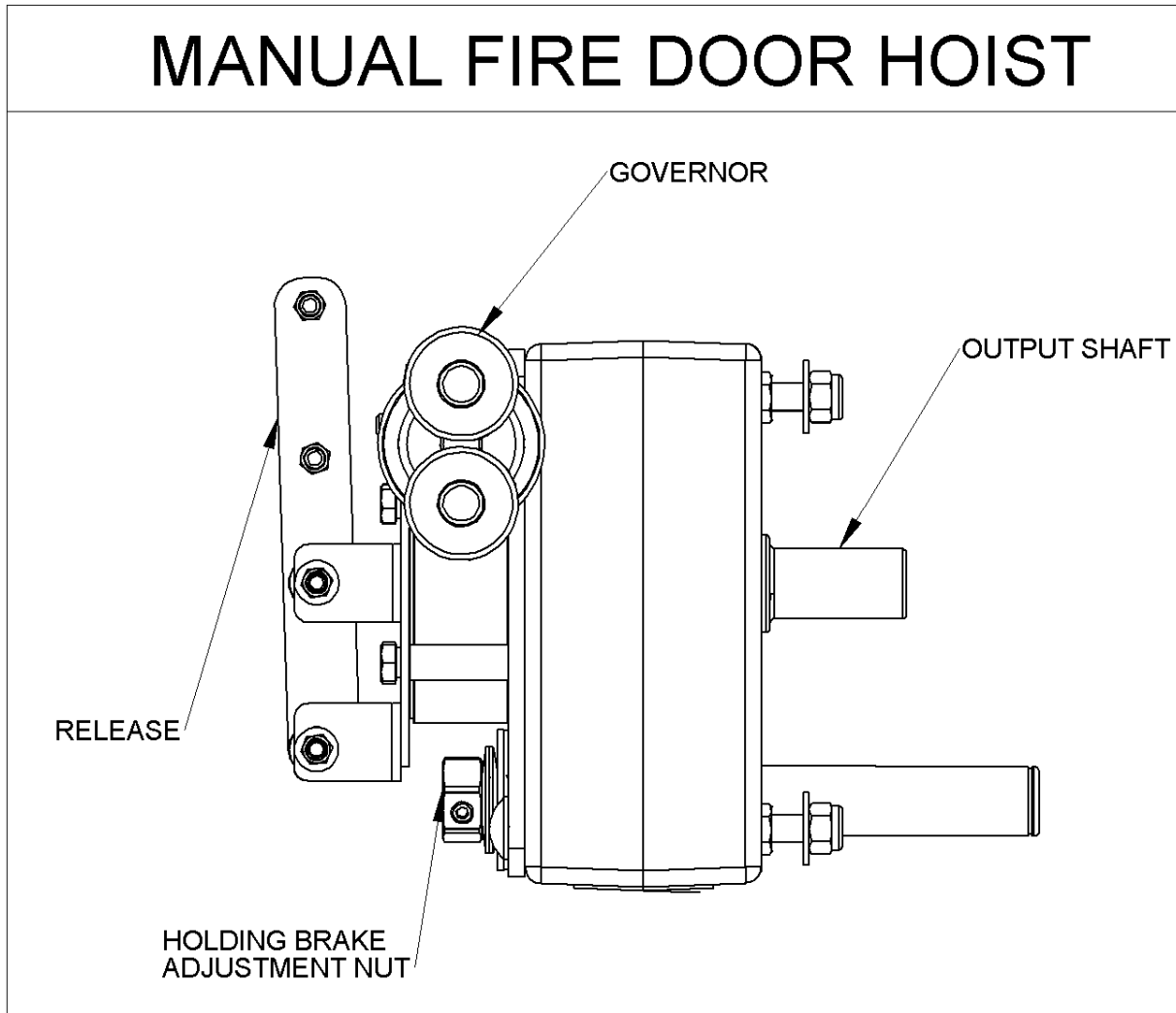

## WARNING

MOVING DOOR, HIGH SPRING TENSION AND ROLLING DRIVE CHAIN CAN ALL CAUSE SERIOUS INJURY OR DEATH.

## INSTALLATION

# NOTICE

IF YOU ARE NOT FAMILIAR WITH THIS PRODUCT PLEASE READ THESE INSTRUCTIONS CAREFULLY BEFORE ATTEMPTING INSTALLATION.

### MOUNTING THE UNIT

The hoist can be mounted either to a one piece head plate or a separate bolt on mounting plate (as pictured below). Using the 4 x M12 nuts and washers provided, ensure the protruding studs pass easily through the chosen mounting bracket.

The unit must be mounted accurately so that the axis of the output shaft is parallel with the axis of the rolling door. Furthermore, the door sprocket must be aligned to the output shaft, such that chain alignment is achieved. Consider that there is only a small allowance for adjustment of the drive sprocket position on the output shaft. Fit the correct length of drive chain around the drive sprocket and plate wheel.

Below are installation examples of the hoist on a live shaft rolling door:

**Left side mount**

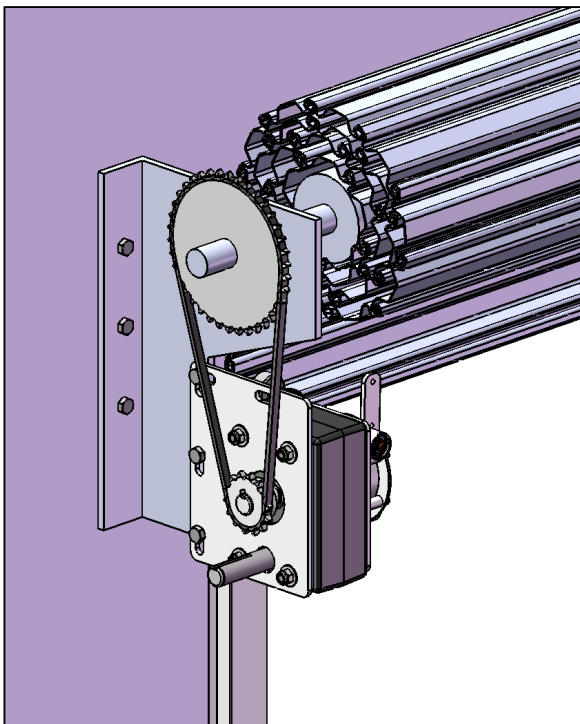

**Right side mount**

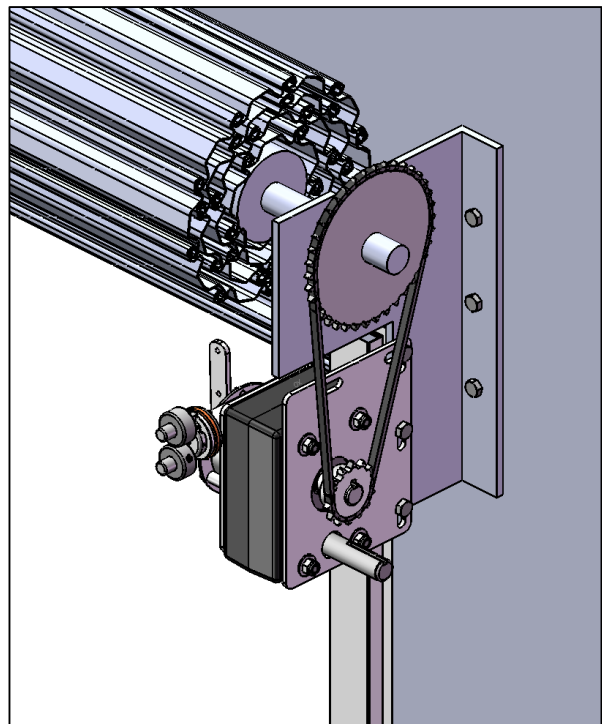

## RELEASE ARM DISENGAGED POSITION

When the release arm has no fusible linkage connected, the spring inside the mechanism will force the arm into its disengaged position. In this position the output shaft is disengaged from the drive sprocket. This is the position of the arm for controlled descent of the rolling door.

## RELEASE ARM ENGAGED POSITION

In this position the output shaft is engaged with the sprocket. This is the position for normal manual operation of the rolling door. To engage the arm, a spring assisted fusible linkage is used. In the engaged position the release arm is parallel to the mounting plate.

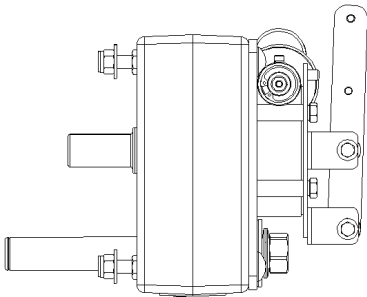
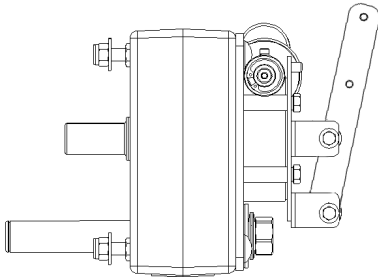
RELEASE ARM POSITIONS	
	<p><b>ENGAGED</b></p> <p>This release arm is being held in this position by a fusible link. This position is for normal operation using the hand chain</p>
	<p><b>DISENGAGED</b></p> <p>If a fire or fire alarm signal causes the fusible link to break, the release arm will disengage and the door will descend</p>

## BOTTOM RAIL WEIGHT AND / OR REVERSE SPRINGING

Depending on the door behavior, there may be a need to add weight to the bottom rail of the door. Alternatively it may be suitable to release some spring tension. This will give the rolling door a bias towards closing when it is in its fully open position.

**Note:** the rolling door must use the radial ball or roller bearings on the rolling door axle

## FUSIBLE LINKAGE CONNECTION

The fusible linkage should be connected in series with the spring (provided) to engage the release arm. The linkage must be arranged so that the force provided to engage the release arm is in a parallel direction to the axis of the output shaft.

## RELEASE ARM SPRING TENSION

When the release arm is in its engaged position, the spring should be stretched to be at least 250mm (10") inches in length.

## TESTING THE SYSTEM

To test the system, engage the release arm and hoist the door 500mm (20") from the closed position with the hand chain. Disengage the release arm and ensure the door closes steadily to the ground.

## ADJUSTING THE CONTROLLED DESCENT SPEED

The speed at which the rolling door falls during controlled descent can be adjusted by moving the governor flyweights. If the flyweights are at their outermost points on their shafts, descent speed will be at its lowest. If they are on their innermost points the descent speed will be at its highest. To move the flyweights, loosen their grub screws with a hex key and slide them into the desired position on their shafts. Tighten the grub screws securely (min. 16Nm).

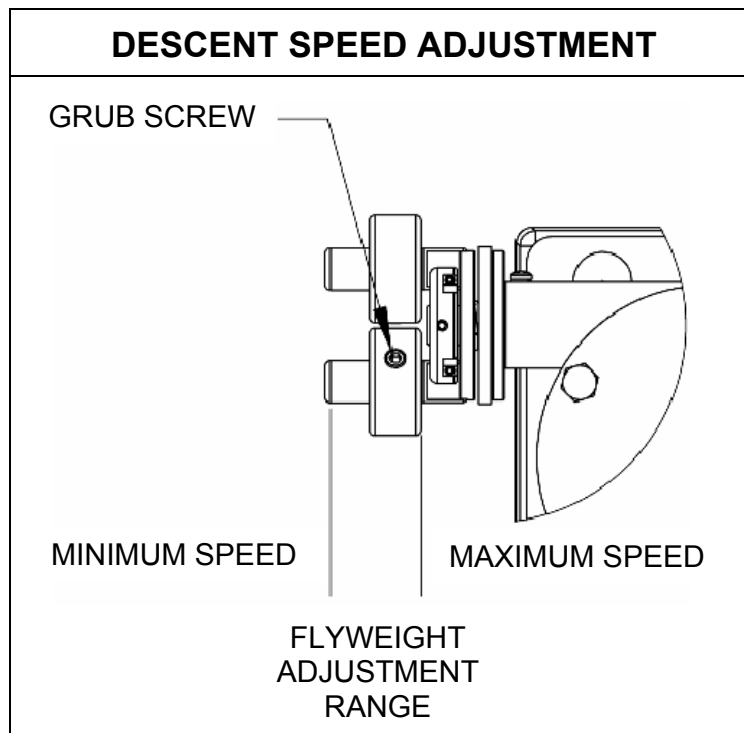

## ADJUSTING THE ROLLING DOOR HOLDING BRAKE

To prevent the rolling door from closing under its own weight during normal operation (release arm engaged), an adjustable holding brake has been provided on the chain wheel shaft. If the above problem is present, loosen the grub screw on the holding brake adjustment nut and tighten the large hex nut enough to ensure that the shutter is held open. Re-tighten the grub screw.

In some instances, the preload required at the holding brake may result in an unacceptably high operating force at the hand chain. If so, consider increasing the chain and sprocket ratio, or increasing the spring balance.



**UNPREDICTABLE BEHAVIOUR OF THE DOOR CURTAIN CAN RESULT FROM MISUSE OF THE HDHWF AND CAN CAUSE PROPERTY DAMAGE OR INJURY.**

## SERVICE AND MAINTENANCE

Testing of the fire door hoist must be carried out in accordance with your local regulations.

All moving parts should be well lubricated, a standard wheel bearing grease will be sufficient. The grease should be applied to the flyweight linkages and the sliding pin when it is extended from the output shaft. An anticorrosion spray should be applied to any vulnerable components.

**Note: Do not grease the friction disc or friction disc plates.**



**FAILURE TO TEST THE FIRE DOOR SYSTEM, INCLUDING THE HOIST, IN ACCORDANCE WITH YOUR LOCAL REGULATIONS COULD RESULT IN SERIOUS INJURY, PROPERTY LOSS OR DEATH.**

## TROUBLESHOOTING GUIDE

<b>PROBLEM</b>	<b>REMEDY</b>
<b>Rolling door will not lift after engaging release arm</b>	<ul style="list-style-type: none"><li>- Increase spring tension on release arm, or remove slack from cable linkage</li></ul>
<b>Rolling door does not descend when mechanism tested</b>	<ul style="list-style-type: none"><li>- Ensure drive chain is aligned between sprockets</li><li>- Ensure drive chain is not over tightened</li><li>- Check for and remove any obstructions from the door guides</li><li>- Increase the weight on the bottom rail</li><li>- Reduce spring tension</li></ul>
<b>Rolling door falls back down when operated</b>	<ul style="list-style-type: none"><li>- Tighten shutter holding brake</li><li>- Ensure release arm fully engaged</li><li>- Increase door spring tension</li></ul>
<b>Rolling door is difficult to raise</b>	<ul style="list-style-type: none"><li>- Check for and remove any obstructions from the door guides</li><li>- Increase the door spring tension</li></ul>

## CHAMBERLAIN 24 MONTH LIMITED WARRANTY

(Excluding electric motors)

Chamberlain Australia Pty Limited / Chamberlain New Zealand Limited (**Seller**) warrants to the original purchaser of the Grifco<sup>™</sup> product (**Unit**) that it is free from defects in material and/or workmanship for a period of 24 months from the date of first purchase from the Seller.

If, during the limited warranty period, the Unit fails due to defects in materials or workmanship Chamberlain will, provided the defective part or Unit is returned freight and insurance prepaid and well packaged to the nearest Chamberlain office, undertake to repair or, at its option, replace any defective part or Unit and return it to the Buyer at no cost. Repairs and replacement parts are warranted for the remaining portion of the original warranty period.

### **Limited warranty on electric motors - 12 months**

In keeping with the manufacturer's warranty, Chamberlain offer a 12 month warranty on all electric motors from the date of purchase. We will furnish a replacement motor free of charge, if it is found to be defective. Labour costs may apply.

Where the Unit has been installed by an authorised installer, Chamberlain will furnish replacement parts free of charge through the authorised installer. Warranty is based on the electric motor/operator being used in conjunction with controls supplied (or other controls authorised in writing prior to installation) by Chamberlain.

### **In-warranty service**

During the warranty period, if the product appears as though it may be defective, call our technical department before removal of the unit. A Chamberlain technician will diagnose the problem and promptly supply you with the parts for "do-it-yourself" repairs, or provide you with shipping instructions for a factory repair or replacement.

If our service centre determines that a warranty claim has been made in respect of a failure or defect arising under or out of any exclusion set out below, we may charge you a fee to repair and/or return the unit to you.

### **Exclusions**

This warranty does not cover any failure of the Unit due to:

1. non-compliance with the instructions regarding installation, operation, maintenance and testing of the Unit or of any product with which the Unit is used.
2. any attempt to repair, dismantle, reinstall or move the Product to another location once the Product is installed by any person other than an authorised installer.
3. tampering, neglect, abuse, wear and tear, accident, electrical storm (force majeure), excessive use or conditions other than normal commercial use.

This warranty does not cover any problems with, or relating to, the commercial door or door hardware, including but not limited to the door slats, door springs, door drum, door alignment or hinges, any problems caused by electrical faults or labour charges for reinstalling a repaired or replaced Unit.

### **Liability – Australia only**

Under no circumstances shall the Seller be liable for consequential, incidental or special damages arising in connection with the use, or inability to use, the Unit. In no event shall the Seller's liability for damages or injury arising from breach of law or contract or for negligence, exceed the cost of repairing or replacing the Unit or refunding the purchase price of the Unit.

Under Division 2 Part V of the *Trade Practices Act, 1974*, certain warranties and conditions (**Implied Terms**) are implied into contracts for the supply of goods or services if the goods or services are of a kind ordinarily acquired for personal, domestic or household use or consumption. Liability for breach of those Implied Terms cannot be excluded or limited and the limitations and exclusions above do not apply to the Implied Terms.

Except for the Implied Terms and the warranties set out above, the Seller excludes all warranties and conditions implied by statute, at law, in fact or otherwise.

### **Liability – New Zealand only**

Except as set out in the *Fair Trading Act 1986* and the *Consumer Guarantees Act 1993*:

- a) all other guarantees, warranties and representations in relation to the Unit or its supply are excluded to the extent that the Seller can lawfully exclude them; and
- b) under no circumstances shall the Seller be liable for consequential, incidental or special damages arising in connection with the use, or inability to use, the Unit, other than those which were reasonably foreseeable as liable to result from the failure.

Chamberlain reserves the right to change the design and specification without prior notification. Some features or accessories may not be available in certain markets or areas.